

**FRONT VIEW**

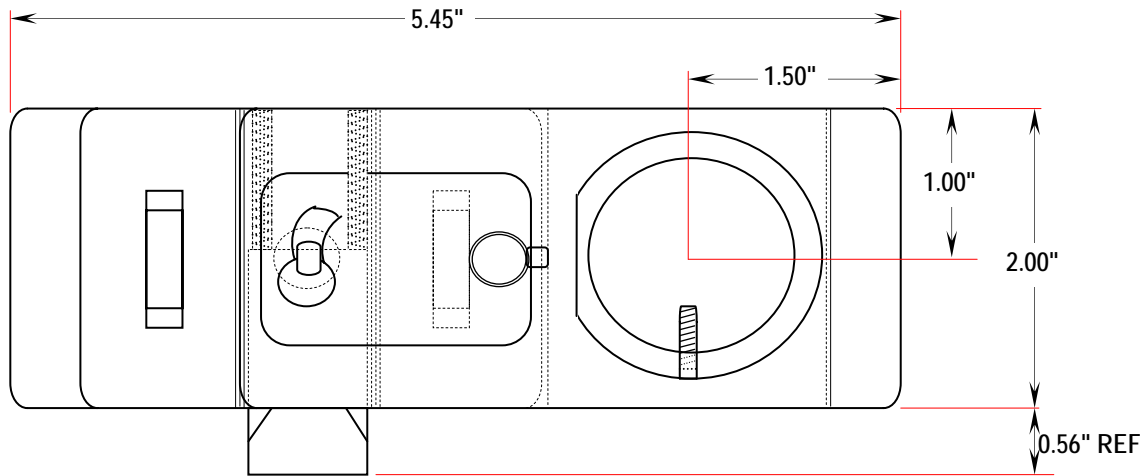

**TOP VIEW**

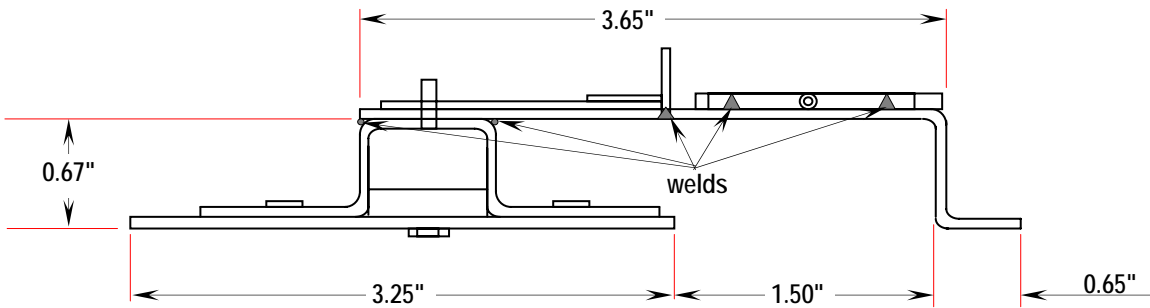
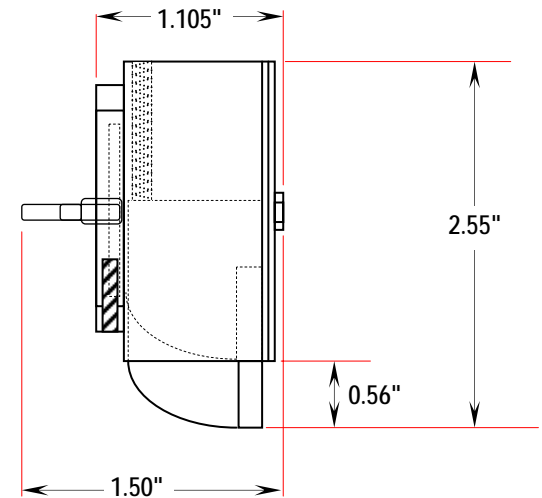

**RIGHT SIDE VIEW**

Notes:

1. Material: Mild Steel, 16GA (0.060")
2. All dimensions in inches
3. Tolerance: +/-0.05" unless otherwise specified
4. All bends are 90°, tolerance +/-1°

A		Origination	
REV.		DESCRIPTION	
 National Fire Equipment Ltd.		40 Edilcan Drive Concord Ontario, L4K 3S6 Phone: (905) 761-6355	
		Date: 5/9/2008	Part Number
Scale: NTS	WB-MLA	Approved: I.S.	
MORTISE LOCK ASSEMBLY			DWG#: MLA-USA