



National Fire Equipment Ltd.

NFE MODEL 15F – 1.5” ANGLE HOSE VALVE

Recommended for use with a swing fire hose rack assembly. Female NPT inlet and Female NPT outlet brass valve with hydrolator. Red handwheel.

Specifications:

- Angle hose valve (Forged brass).
- Female x Female hose connection with hydrolator.
- Red handwheel.
- Rated Pressure: 300PSI
- Recommended for use with swing style fire hose rack assemblies.

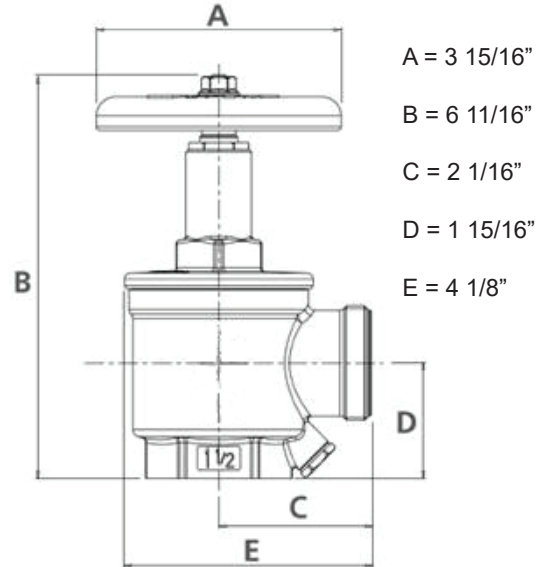

15F Standard Brass



15F Satin Chrome Finish



15F Polished Chrome Finish



National Fire
Equipment Ltd.

TORONTO: (905) 761-6355
Toll Free: (800) 267-8508

OTTAWA: (613) 723-6071

VANCOUVER: (604) 420-1131
Toll Free: (800)-667-2138

BURNABY: (604)-299-4498

EDMONTON: (780) 455-3870
Toll Free: (888)-891-1008

CALGARY: (403) 236-5661

MONCTON: (506) 859-7277
Toll Free: (877) 816-3473

MISSISSAUGA: (905) 565-1385

www.nationalfire.com