

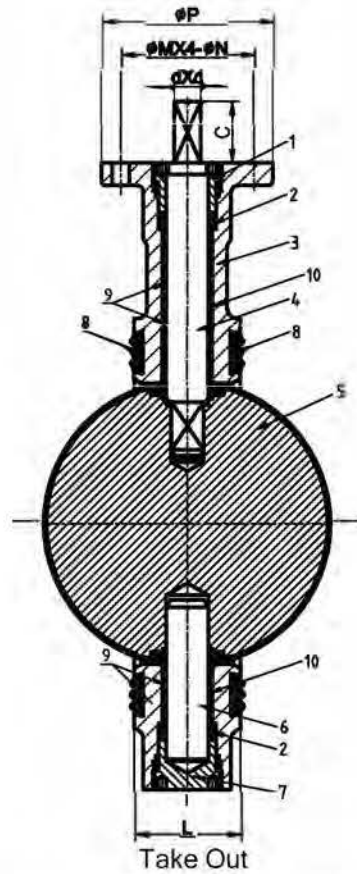

National Fire Equipment Ltd.

**Model BFWO & BFWC Wafer Supervised
Butterfly Valve 2.5" - 8" (300PSI) (Normally Open & Closed)**

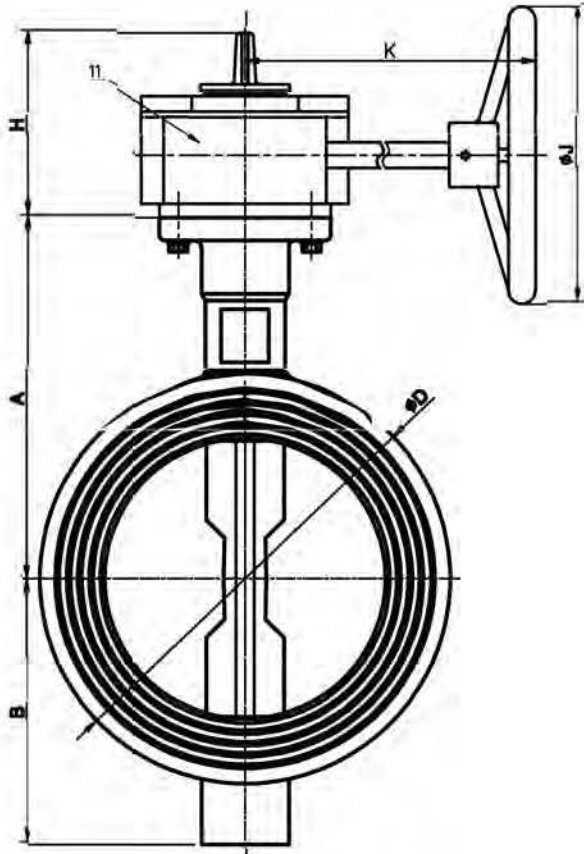

Normally Open Butterfly Valves

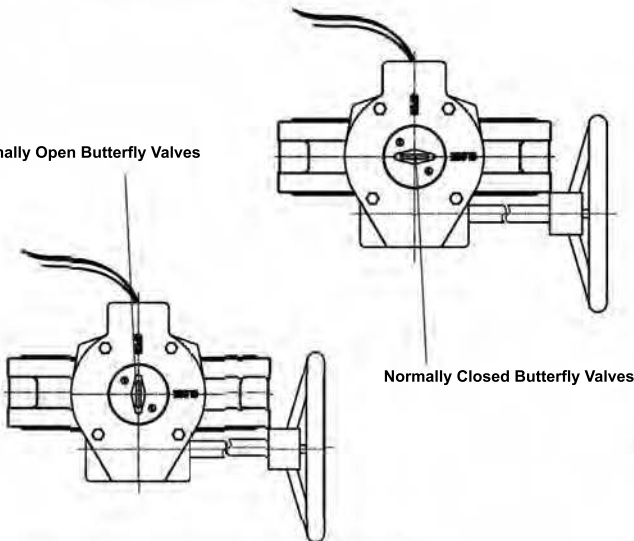

Normally Closed Butterfly Valves

11	Gear Box		
10	O-Ring	EPDM	ASTM D2000
9	Stem Bushing	PTFE/C954	
8	End Face Seal	EPDM	ASTM D2000
7	Lower Shaft Sealing Nut	WCB	ASTM A216
6	Lower Shaft	SS416	ASTM A582
5	Disc	DI+EPDM	
4	Upper Shaft	SS416	ASTM A582
3	Body	DI	ASTM A536
2	Shaft Seal	EPDM	ASTM D2000
1	Upper Shaft Sealing Nut	WCB	ASTM A216
NO.	Name	Material	Remark

Design Standard	API 609
Face to Face Standard	ASME B16.1
Top Flange Standard	ISD 5211
Test Standard	API 598

Valves **Dimension Chart in mm** Take Out

SIZE	A	B	C	D	H	K	J	P	M	N	d	L	
2.5"	125	95	32	112	111	153	218	152	90	70	9	10	44.2
3"	140	100	32	120	111	153	218	152	90	70	9	11	45.3
4"	160	100	32	161	111	153	218	152	90	70	9	14	52
6"	190	140	32	216	111	153	218	200	90	70	9	16	55.8
8"	230	175	32	260	126	210	232	300	125	102	12	19	60.5

Max working pressure: 300 PSI (Max testing pressure : 600 PSI)
All valves are *UL/ULC listed and F.M. approved up to 300 PSI

Valve is painted epoxy powder coating.
Meets the requirements of NSF/ANSI Standard 61

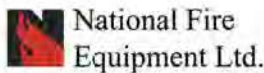

TORONTO: (905) 761-6355
Toll Free: (800) 267-8508
OTTAWA: (613) 723-6071

VANCOUVER: (604) 420-1131
Toll Free: (800)-667-2138
BURNABY: (604)-299-4498

EDMONTON: (780) 455-3870
Toll Free: (888)-891-1008
CALGARY: (403) 236-5661

MONCTON: (506) 859-7277
Toll Free: (877) 816-3473
MISSISSAUGA: (905) 565-1385

www.nationalfire.com

05062026

FULLY OPEN

SUPERVISORY SWITCH

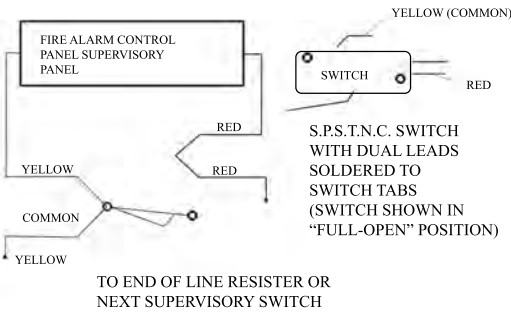

FULLY CLOSE

SUPERVISORY SWITCH

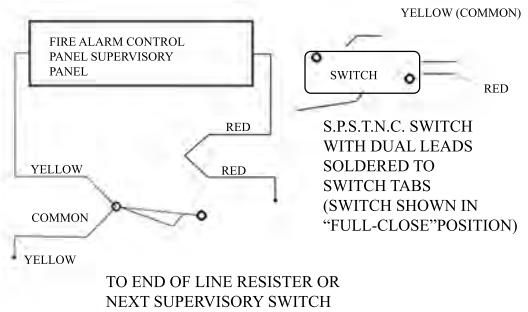

AUXILIARY SWITCH

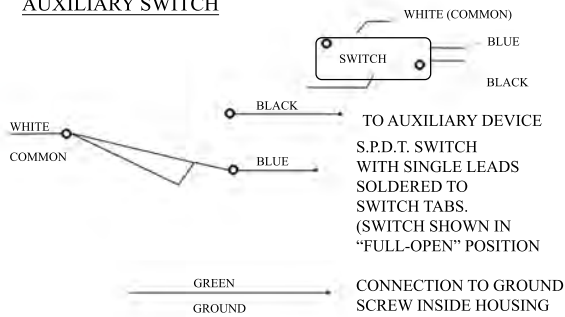

AUXILIARY SWITCH

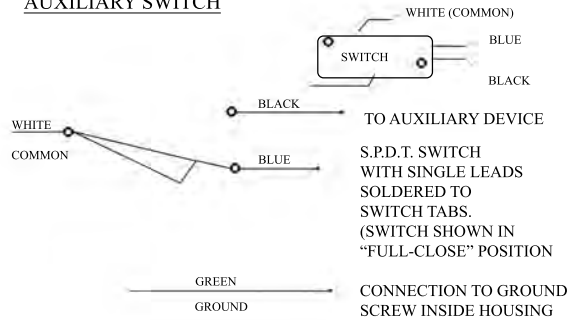

PRESSURE DROP (PSI) VS. (GPM)

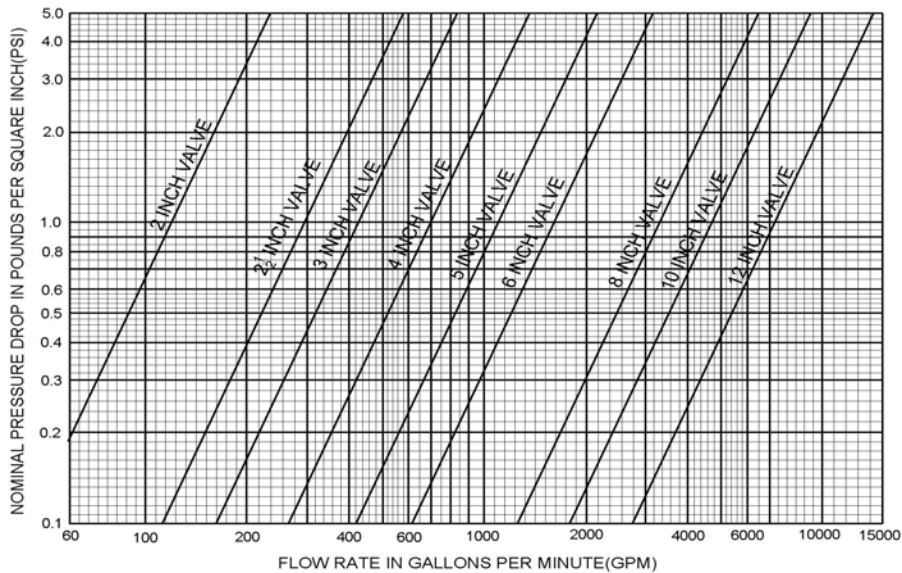

No.	Description	Weight (KG)	No.	Description	Weight (KG)
BFWO250	BUTTERFLY WAFER 2.5"	8.7	BFWC250	BUTTERFLY WAFER 2.5" NORMALLY CLOSED	8.7
BFWO300	BUTTERFLY WAFER 3"	8.8	BFWC300	BUTTERFLY WAFER 3" NORMALLY CLOSED	8.8
BFWO400	BUTTERFLY WAFER 4"	10.8	BFWC400	BUTTERFLY WAFER 4" NORMALLY CLOSED	10.8
BFWO600	BUTTERFLY WAFER 6"	14.6	BFWC600	BUTTERFLY WAFER 6" NORMALLY CLOSED	14.6
BFWO800	BUTTERFLY WAFER 8"	26.7	BFWC800	BUTTERFLY WAFER 8" NORMALLY CLOSED	26.7

*UL/ULC certificate number EX16383. FM approval identification number 3044634.

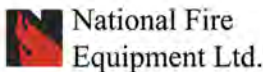

TORONTO: (905) 761-6355
Toll Free: (800) 267-8508

OTTAWA: (613) 723-6071

VANCOUVER: (604) 420-1131
Toll Free: (800)-667-2138

BURNABY: (604)-299-4498

EDMONTON: (780) 455-3870
Toll Free: (888)-891-1008

CALGARY: (403) 236-5661

MONCTON: (506) 859-7277
Toll Free: (877) 816-3473

MISSISSAUGA: (905) 565-1385

www.nationalfire.com

05062026