



National Fire Equipment Ltd.

PREMIUM ACCESS DOORS



National Fire
Equipment Ltd.

TORONTO: (905) 761-6355
Toll Free: (800) 267-8508

OTTAWA: (613) 723-6071

VANCOUVER: (604) 420-1131
Toll Free: (800)-667-2138

BURNABY: (604)-299-4498

EDMONTON: (780) 455-3870
Toll Free: (888)-891-1008

CALGARY: (403) 236-5661

MONCTON: (506) 859-7277
Toll Free: (877) 816-3473

MISSISSAUGA: (905) 565-1385

www.nationalfire.com



National Fire Equipment Ltd.

Table of Contents

WBGP PREMIUM GENERAL PURPOSE ACCESS DOOR	1
WBUAD UTILITY ACCESS DOOR	2
WBBASIC ACCESS DOOR & WBNT NO TRIM ACCESS DOOR	3
WBWP REMOVABLE PANEL ACCESS DOOR & WBSMP SURFACE MOUNTED PANEL ACCESS DOOR	4
WBAL ALUMINUM INSULATED ACCESS DOOR & WB-ALU ALUMINUM UNINSULATED ACCESS DOOR	5
WBFR STANDARD FIRE RATED ACCESS DOOR	6
WBFR BASIC UNINSULATED FIRE RATED ACCESS DOOR	7
WBFR STANDARD DRYWALL FIRE RATED ACCESS DOOR & WBFR STANDARD PLASTER FIRE RATED ACCESS DOOR	8
WBDW DRYWALL ACCESS DOOR & WBRDW RECESSED DRYWALL ACCESS DOOR	9
WBPL PLASTER ACCESS DOOR & WBAP ACOUSTICAL PLASTER ACCESS DOOR	10
WBAT ACOUSTICAL TILE ACCESS DOOR & WB-T-BAR CEILING ACCESS DOOR	11
WBMS MEDIUM SECURITY ACCESS DOOR & WBHS HIGH SECURITY ACCESS DOOR	12
WBEXT EXTERIOR T HANDLE ACCESS DOOR & WBWTD WALK THROUGH ACCESS DOOR	13
WBMAP PLASTIC MULTI-FUNCTIONAL ACCESS DOOR & WBGYP GYPSUM PANEL ACCESS DOOR	14
WBNTG TRIMLESS GYPSUM ACCESS DOOR	15
ACCESSORIES	16

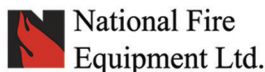

National Fire
Equipment Ltd.

TORONTO: (905) 761-6355
Toll Free: (800) 267-8508

OTTAWA: (613) 723-6071

VANCOUVER: (604) 420-1131
Toll Free: (800)-667-2138

BURNABY: (604)-299-4498

EDMONTON: (780) 455-3870
Toll Free: (888)-891-1008

CALGARY: (403) 236-5661

MONCTON: (506) 859-7277
Toll Free: (877) 816-3473

MISSISSAUGA: (905) 565-1385

www.nationalfire.com



National Fire Equipment Ltd.

WBGP PREMIUM GENERAL PURPOSE ACCESS DOOR



The WBGP Premium General Purpose Access Door is a precision-flush access door for wall and ceiling applications. The frame is laser cut from one sheet of cold rolled steel with no corner mitering and is the aesthetic preference of architects and building professionals alike.

Door and Trim	14 ga. cold rolled steel, trim 1 1/2" wide
Return Frame	18 ga. cold rolled steel, depth of 1 3/4"
Hinge	Fully-concealed off set hinge. Allows opening to 170°. Number of hinges varies with size of door and will be placed on long side of door unless otherwise requested.
Latch	Flush, stainless steel cam operated with screwdriver. Doors over 24" will have semi-concealed piano-type hinge.
Finish	White powder coat paintable finish
Options (at extra cost)	<ul style="list-style-type: none"> • Tamper Proof Cams, Hex, Torx Pin Screw Assembly • Key Cylinder Lock with key (code 151) • Mortise Lock Preparation • Air-tight Neoprene Gasketing • Stainless Steel #304 or #316 (#4 satin finish) • Galvanized/Zinc Coating Finish • Masonry Anchor Straps • Custom Sizes Available

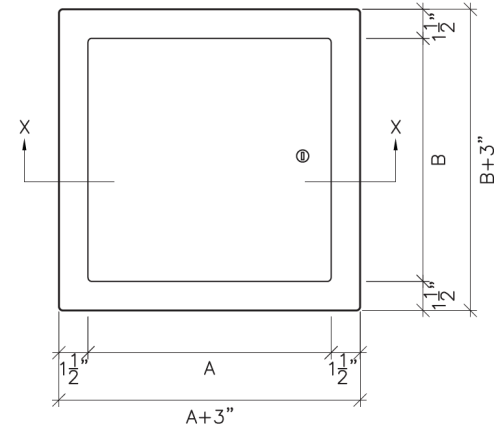

Elevation

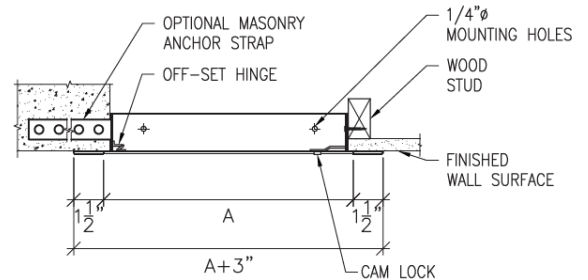

Section Detail

Model No.	A x B Door Size	Hinges	Cam Latch	Shipping Weight (lbs) Steel/Stainless
WBGP-66	6" x 6"	1	1	4
WBGP-88	8" x 8"	1	1	5
WBGP-812	8" x 12"	1	1	6
WBGP-816	8" x 16"	2	3	8
WBGP-1010	10" x 10"	1	1	6
WBGP-1212	12" x 12"	1	3	8
WBGP-1216	12" x 16"	2	3	10
WBGP-1218	12" x 18"	2	3	11
WBGP-1224	12" x 24"	3	4	14
WBGP-1414	14" x 14"	2	3	10
WBGP-1616	16" x 16"	2	3	13
WBGP-1620	16" x 20"	3	3	16
WBGP-1624	16" x 24"	3	4	17
WBGP-1818	18" x 18"	3	3	14
WBGP-1824	18" x 24"	3	4	18
WBGP-1836	18" x 36"	PH	5	29

Model No.	A x B Door Size	Hinges	Cam Latch	Shipping Weight (lbs) Steel/Stainless
WBGP-2020	20"x20"	3	3	17
WBGP-2024	20"x24"	3	4	21
WBGP-2030	20"x30"	PH	4	23
WBGP-2222	22"x22"	3	4	22
WBGP-2224	22"x24"	3	4	23
WBGP-2230	22"x30"	PH	4	25
WBGP-2236	22"x36"	PH	5	32
WBGP-2424	24"x24"	3	4	24
WBGP-2430	24"x30"	PH	4	27
WBGP-2436	24"x36"	PH	5	35
WBGP-2448	24"x48"	PH	6	43
WBGP-3030	30"x30"	PH	6	32
WBGP-3036	30"x36"	PH	7	39
WBGP-3636	36"x36"	PH	9	44
WBGP-3648	36"x48"	PH	10	57
WBGP-4848	48"x48"	PH	12	70

Rough wall opening = door size + 1/4"

PH = Full length piano hinge

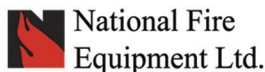

TORONTO: (905) 761-6355
Toll Free: (800) 267-8508

VANCOUVER: (604) 420-1131
Toll Free: (800)-667-2138

EDMONTON: (780) 455-3870
Toll Free: (888)-891-1008

MONCTON: (506) 859-7277
Toll Free: (877) 816-3473

OTTAWA: (613) 723-6071

BURNABY: (604)-299-4498

CALGARY: (403) 236-5661

MISSISSAUGA: (905) 565-1385

www.nationalfire.com



National Fire Equipment Ltd.

WBUAD UTILITY ACCESS DOOR



Door and Trim	16 ga. cold rolled steel, trim 1 1/2" wide
Return Frame	16 ga. cold rolled steel, depth of 1 3/4"
Hinge	Spring pin hinge up to 24" x 24" Piano hinge on doors larger than 24" x 24"
Latch	Flush, stainless steel cam operated with screwdriver. Latches are positioned opposite hinge as well as top and bottom on larger sizes.
Finish	White powder coat paintable finish
Options (at extra cost)	<ul style="list-style-type: none"> • Tamper Proof Cams, Hex, Torx Pin screw assembly • Key Cylinder Lock with key (code 151) • Mortise Lock Preparation • Stainless Steel #304 or #316 (#4 satin finish) • Galvanized/Zinc Coating Finish • Custom Sizes Available

The WBUAD Utility Access Door is an innovative, cost-effective access door. This door is laser cut from 16-gauge cold rolled steel and of unwelded construction that allows for an aesthetically pleasing appearance and square fit for wall and ceiling applications. This door features a spring-loaded pin hinge that allows the door panel to be removed.

Model No.	A x B Door Size	Cam Latch	Shipping Weight (lbs) Steel/Stainless
WBUAD-66	6" x 6"	1	1
WBUAD-88	8" x 8"	1	3
WBUAD-812	8" x 12"	1	4.1
WBUAD-1010	10" x 10"	1	4.1
WBUAD-1212	12" x 12"	1	5
WBUAD-1414	14" x 14"	3	6
WBUAD-1616	16" x 16"	3	6.8
WBUAD-1818	18" x 18"	3	10
WBUAD-1824	18" x 24"	3	14.1
WBUAD-2020	20" x 20"	3	11
WBUAD-2222	22" x 22"	4	14.4
WBUAD-2230	22" x 30"	4	16.1
WBUAD-2236	22" x 36"	5	17.1
WBUAD-2424	24" x 24"	4	15
WBUAD-2430	24" x 30"	4	19.5
WBUAD-2436	24" x 36"	5	22.5
WBUAD-2448	24" x 48"	6	30
WBUAD-3030	30" x 30"	6	24
WBUAD-3636	36" x 36"	9	34

Rough wall opening = door size + 1/8"

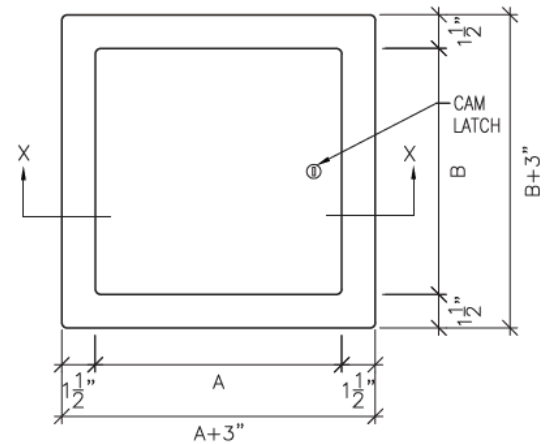

Elevation

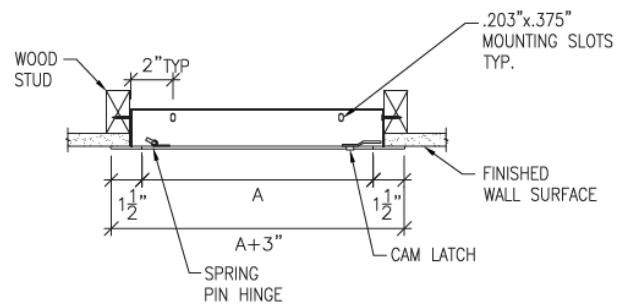

Section Detail



National Fire Equipment Ltd.

WBBASIC ACCESS DOOR & WBNT NO TRIM ACCESS DOOR



Door and Trim	18 ga. satin coat galvanized steel
Return Frame	18 ga. satin coat galvanized steel
Hinge	Pin hinge top and bottom Allows opening to 165°. Piano hinge on doors larger than 24" x 24"
Latch	Flush, stainless steel cam operated with screwdriver. Latches are positioned opposite hinge as well as top and bottom on larger sizes.

Finish	White powder coat paintable finish
Options (at extra cost)	<ul style="list-style-type: none"> • Key Cylinder Lock with key (code 151) • Stainless Steel #304 or #316 (#4 satin finish)

*Piano hinge on doors larger than 24" x 24"

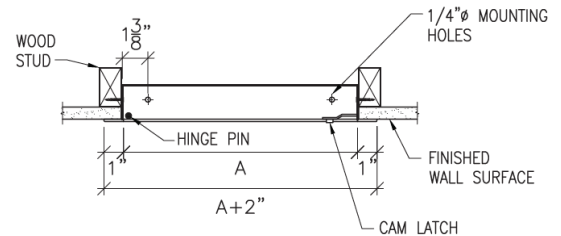

The WB-Basic Access Door is a cost-effective solution, perfect for bidding on any project. This door is manufactured from satin coat galvanized steel, powder coat white and available in a range of popular sizes, ready for installation. It is easily installed using prelocated mounting holes.

Model No.	A x B Door Size	Cam Latch	Shipping Weight (lbs) Steel/Stainless
WBBASIC-66	6 x 6"	1	2
WBBASIC-88	8 x 8"	1	3
WBBASIC-1010	10 x 10"	1	4
WBBASIC-1212	12 x 12"	1	5
WBBASIC-1414	14 x 14"	3	6
WBBASIC-1616	16 x 16"	3	8

Model No.	A x B Door Size	Cam Latch	Shipping Weight (lbs) Steel/Stainless
WBBASIC-1818	18 x 18"	3	11
WBBASIC-2222	22"x22"	4	15
WBBASIC-2424	24"x24"	4	17
WBBASIC-2436	24"x36"	5	16
WBBASIC-2448	24"x48"	6	23
WBBASIC-3030	30"x30"	6	19

Rough wall opening = door size + 1/4"



Door and Trim	16 ga. cold rolled steel
Return Frame	18 ga. cold rolled steel
Hinge	Fully concealed off-set hinge
Latch	Flush, stainless steel cam
Finish	White powder coat paintable finish

Options (at extra cost)	<ul style="list-style-type: none"> • Tamper Proof Cam Hex, Torx Pin Screw Assembly • Key Cylinder Lock with key (code 151) • Mortise Lock Preparation • Stainless Steel #304 or #316 (#4 satin finish)
-------------------------	--------------------------------------------------------------------------------------------------------------------------------------------------------------------------------------------------------------------------------------------------

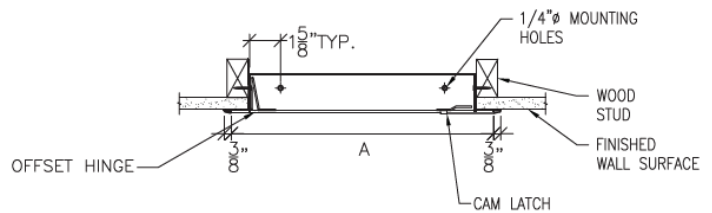

The WBNT No Trim Access Door features a seamless look. An attractive beveled edge door and micro-rounded corners make this an architect favorite. The door features an off-set hinge that allows it to open 180 degrees, while completely hiding the frame from view.

Model No.	A x B Door Size	Cam Latch	Shipping Weight (lbs) Steel/Stainless
WBNT-88	8 x 8"	1	3
WBNT-1010	10 x 10"	1	4
WBNT-1212	12 x 12"	1	6
WBNT-1414	14 x 14"	1	7
WBNT-1616	16 x 16"	1	9

Model No.	A x B Door Size	Cam Latch	Shipping Weight (lbs) Steel/Stainless
WBNT-1818	18 x 18"	3	10
WBNT-2020	20"x20"	3	13
WBNT-2222	22"x22"	4	15
WBNT-2424	24"x24"	4	17

Rough wall opening = door size + 1/4"

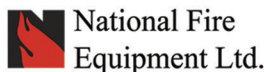

TORONTO: (905) 761-6355
Toll Free: (800) 267-8508
OTTAWA: (613) 723-6071

VANCOUVER: (604) 420-1131
Toll Free: (800)-667-2138
BURNABY: (604)-299-4498

EDMONTON: (780) 455-3870
Toll Free: (888)-891-1008
CALGARY: (403) 236-5661

MONCTON: (506) 859-7277
Toll Free: (877) 816-3473
MISSISSAUGA: (905) 565-1385

www.nationalfire.com



National Fire Equipment Ltd.

WBRP REMOVABLE PANEL ACCESS DOOR & WBSMP SURFACE MOUNTED PANEL ACCESS DOOR



Door and Trim	14 ga. steel, trim 1 1/2" wide
Return Frame	18 ga. steel, depth of 1 3/4"
Latch	Flush, stainless steel cam operated with screwdriver on all 4 sides
Finish	White powder coat paintable finish

Options (at extra cost)	<ul style="list-style-type: none"> • Tamper Proof Cams, Hex, Torx Pin Screw Assembly • Key Cylinder Lock with key (code 151) • Mortise Lock Preparation • Air-Tight Neoprene Gasketing • Stainless Steel #304 or #316 (#4 satin finish) • Galvanized/Zinc Coating Finish • Masonry Anchor Straps • Custom Sizes Available

The WBRP Removable Panel Access Door is designed with the same quality features as the GP Premium Door, but it is primarily designed for use in confined spaces. The door panel can be easily removed by unscrewing the cam latches. The frame is laser cut from one sheet of steel for visual aesthetics. As an optional feature, gasketing allows this door to be used for an air tight or dust free application.

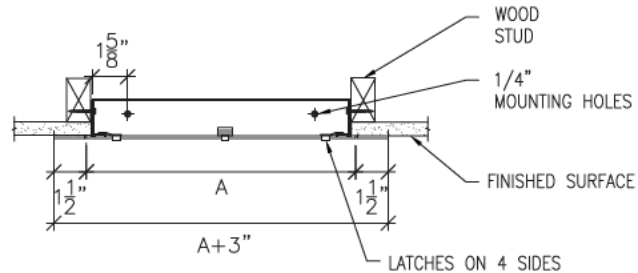

Model No.	A x B Door Size	Cam Latch	Shipping Weight (lbs)
WBRP-88	8" x 8"	4	3
WBRP-1212	12" x 12"	4	8
WBRP-1616	16" x 16"	4	10

Model No.	A x B Door Size	Cam Latch	Shipping Weight (lbs)
WBRP-1818	18 x 18"	4	13
WBRP-2424	24"x24"	8	20

Rough wall opening = door size + 1/4"



Door and Trim	14 ga. steel, trim 1 1/2" wide
Return Frame	16 ga. on 3 sides of door opening
Hinge	Full length piano hinge allows door to be opened to 180°. Will be placed on long side of door unless otherwise requested.
Latch	Flush, stainless steel cam operated with screwdriver. Latches are positioned opposite hinge as well as on top and bottom on larger sizes.
Finish	White powder coat paintable finish

Options (at extra cost)	<ul style="list-style-type: none"> • Tamper Proof Cams, Hex, Torx Pin Screw Assembly • Key Cylinder Lock with key (code 151) • Mortise Lock Preparation • Neoprene Gasketing • Stainless Steel #304 or #316 (#4 satin finish) • Galvanized/Zinc Coating Finish • Masonry Anchor Straps • Custom Sizes Available

The WBSMP Surface Mounted Panel Access Door is a door face only, with no return frame. It does not require a framed opening, making it simple to install over any wall and ceiling openings. The door's frame is laser cut from one sheet of steel for visual aesthetics.

Model No.	A x B Door Size	Wall Opening	Cam Latch	Shipping Weight (lbs) Steel/Stainless
WBSMP-88	8" x 8"	TO SUIT DOOR PANEL	1	4
WBSMP-1212	12" x 12"		3	5
WBSMP-1616	16" x 16"		3	10
WBSMP-1818	18" x 18"		3	14
WBSMP-2424	24" x 24"		4	18

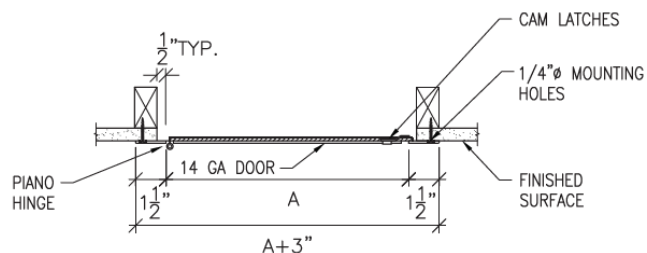



National Fire Equipment Ltd.

WBAL ALUMINUM INSULATED ACCESS DOOR & WBALU ALUMINUM UNINSULATED ACCESS DOOR



Model No.	A x B Door Size	Cam Latch	Shipping Weight (lbs) Steel/Stainless
WBAL-88	8"x8"	1	3.5
WBAL-1212	12"x12"	3	6
WBAL-1616	16"x16"	3	9
WBAL-1818	18"x18"	3	15
WBAL-2424	24"x24"	4	24
WBAL-2436	24"x36"	5	45

Rough wall opening = door size + 1/4"

Door and Trim	.063 Aluminum, trim 1 1/2" wide
Return Frame	.063 Aluminum, depth of 2"
Hinge	Continuous rod hinge
Latches	Flush aluminum steel cam
Insulation	1" AMVIC SilveRboard Ridge Foam Insulation with a R5 Value
Gasket	Neoprene gasket included on 4 sides
Finish	Mill finish
Options (at extra cost)	Key medium barrel cylinder Lock with key (code 151)

The WBAL Aluminum Insulated Access Door is a light weight insulated aluminum access door. It is ideal for exterior applications, and also those specific interior applications where corrosion or moisture is a concern. The aluminum panel is insulated with 1" SilveRboard Ridge Foam Insulation. Access to large openings in walls and ceilings is made easy. The non-extruded door frame has the same visual aesthetic design as the UAD door. Weather resistant neoprene gasketing is installed on 4 sides.

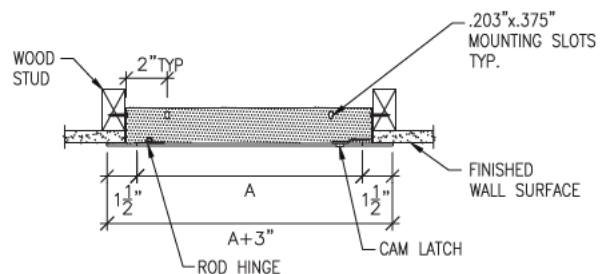

Door and Trim	.060 Aluminum, trim 1 3/4" wid
Return Frame	.060 Aluminum, depth of 1 1/16"
Hinge	Full length piano hinge
Latches	Flush aluminum cam
Finish	White powder coat paintable finish
Options (at extra cost)	<ul style="list-style-type: none"> • Key cylinder lock with key (code 151) • Neoprene Gasketing

The WB-ALU Uninsulated Aluminum Access Door is a lightweight aluminum access door for wall and ceiling application. Its surround trim is welded on all 4 sides to the return frame providing strength and rigidity. It features radius corners and no corner mitering. Its aesthetic appearance makes it an architect favorite.

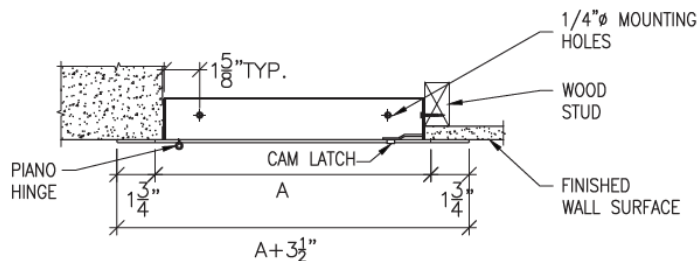

Model No.	A x B Door Size	Cam Latch	Shipping Weight (lbs) Steel/Stainless
WBALU-66	6"x6"	1	2.5
WBALU-88	8"x8"	1	3.5
WBALU-812	8"x12"	1	5
WBALU-1010	10"x10"	1	5
WBALU-1212	12"x12"	1	6
WBALU-1216	12"x16"	3	7.5
WBALU-1218	12"x18"	3	8
WBALU-1224	12"x24"	3	10
WBALU-1414	14"x14"	3	7.5
WBALU-1616	16"x16"	3	9
WBALU-1818	18"x18"	3	15
WBALU-1824	18"x24"	4	13
WBALU-1836	18"x36"	5	29
WBALU-2020	20"x20"	3	19
WBALU-2222	22"x22"	4	21
WBALU-2230	22"x30"	5	27
WBALU-2236	22"x36"	5	30
WBALU-2424	24"x24"	4	24
WBALU-2430	24"x30"	4	28
WBALU-2436	24"x36"	5	32
WBALU-2448	24"x48"	6	40
WBALU-3030	30"x30"	6	34
WBALU-3636	36"x36"	9	45
WBALU-3648	36"x48"	10	57
WBALU-4848	48"x48"	12	70

Rough wall opening = door size + 1/4"



**National Fire
Equipment Ltd.**

TORONTO: (905) 761-6355
Toll Free: (800) 267-8508

OTTAWA: (613) 723-6071

VANCOUVER: (604) 420-1131
Toll Free: (800)-667-2138

BURNABY: (604)-299-4498

EDMONTON: (780) 455-3870
Toll Free: (888)-891-1008

CALGARY: (403) 236-5661

MONCTON: (506) 859-7277
Toll Free: (877) 816-3473

MISSISSAUGA: (905) 565-1385

www.nationalfire.com



National Fire Equipment Ltd.

WBFR STANDARD FIRE RATED ACCESS DOOR



WBFR S

The WBFR Standard Fire Rated Access Door is designed for both wall and ceiling applications. This door has an Underwriters Laboratories (UL and ULC), 1-1/2 hour "B" label, with a maximum temperature rise of 250 degrees Celsius after 30 minutes for vertical wall installations. File # R10364. Warnock Hersey International; Pittsburgh, CA 1 hr rating for combustible floor/ceiling applications. Report. # WHI-495-PSH-0191. Warnock Hersey International, Pittsburgh, CA 3 Hr. rating for non-combustible floor/ceiling assembly, Report # WHI-495-PSH-0192. This door may be used in a 2-hour fire rated wall assembly. For fire rated ceilings, this door has been approved by Warnock Hersey International for 3 hours (*max. size to 24" x 36").

Door and Trim	18 ga. cold rolled steel
Box Return Frame	16 ga. cold rolled steel
Insulation	2" thick mineral wool contained within door cavity
Hinge	Fully concealed rod type hinge. Allows opening to 170°.
Latch	Self-latching direct-action latch, opposite hinge. Accepts both key and knurled knob, included with each door.
Automatic Panel Closer	Standard on all doors
Inside Panel Release	Standard on all doors
Finish	White powder coat paintable finish
Masonry Anchor Straps	Standard on all doors
Options (at extra cost)	<ul style="list-style-type: none"> • Mortise lock preparation • Stainless steel #304 and #316 (#4 satin finish) • Pemko hot smoke seal gasketing • Custom sizes available
Ceiling Installation	To comply with current fire regulations, largest size acceptable is 24" x 36"

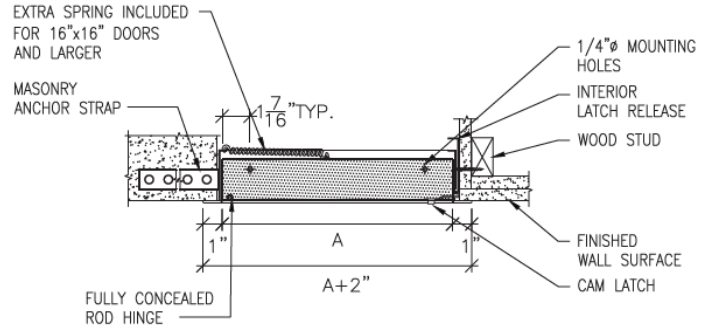

WBFR STANDARD ULTRA FIRE RATED ACCESS DOOR



The WBFR Standard Ultra Access Door features a paddle latch with WB 151 key cylinder lock.



WBFR S ULTRA

WBFR STANDARD AND ULTRA ACCESS DOORS

For WBFR Standard use WBFRS

For WBFR Ultra use WBFRSU

Model No.	A x B Door Size	Slam Catch	Hinges	Shipping Weight (lbs) Steel/Stainless
WBFRS-88	8"x8"	1	1	7
WBFRS-1010	10"x10"	1	1	10
WBFRS-1212	12"x12"	1	1	11
WBFRS-1218	12"x18"	1	1	19
WBFRS-1224	12"x24"	1	1	18
WBFRS-1414	14"x14"	1	1	15
WBFRS-1616	16"x16"	1	1	18
WBFRS-1818	18"x18"	1	1	21
WBFRS-1824	18"x24"	1	1	26
WBFRS-2020	20"x20"	1	1	26
WBFRS-2030	20"x30"	2	1	38
WBFRS-2136	21"x36"	2	1	43
WBFRS-2222	22"x22"	1	1	29
WBFRS-2224	22"x24"	1	1	30
WBFRS-2230	22"x30"	2	1	37

Model No.	A x B Door Size	Slam Catch	Hinges	Shipping Weight (lbs) Steel/Stainless
WBFRS-2236	22"x36"	2	1	43
WBFRS-2424	24"x24"	1	1	31
WBFRS-2430	24"x30"	2	1	40
WBFRS-2436	24"x36"	2	1	46
WBFRS-2448	24"x48"	2	1	62
WBFRS-3030	30"x30"	2	1	50
WBFRS-3232	32"x32"	2	1	54
WBFRS-3636	36"x36"	2	1	67
WBFRS-3636	36"x48"	2	1	83
WBFRS-4848	48"x48"	2	1	104

Rough wall opening = door size + 1/4"

Note: For fire-rated ceiling access doors, on size 16" x 16" and larger, extra spring supplied with door must be attached from back of door pan to framing or floor above. In horizontal (ceiling) applications door has self-assisted closing.

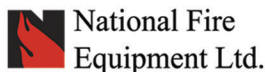

TORONTO: (905) 761-6355
Toll Free: (800) 267-8508

VANCOUVER: (604) 420-1131
Toll Free: (800)-667-2138

EDMONTON: (780) 455-3870
Toll Free: (888)-891-1008

MONCTON: (506) 859-7277
Toll Free: (877) 816-3473

OTTAWA: (613) 723-6071

BURNABY: (604)-299-4498

CALGARY: (403) 236-5661

MISSISSAUGA: (905) 565-1385

www.nationalfire.com



National Fire Equipment Ltd.

WBFR BASIC UNINSULATED FIRE RATED ACCESS DOOR



The WB-FR Basic Uninsulated Fire Rated Access Door is designed for wall application only. It is not insulated and should only be installed in environments where temperature rise is not a concern. It features a 1 1/2" trim for an easy flush application into various wall finishes. UL Listed "B" label for 1-1/2 hours. File # R10364C UL US.



Door and Trim	14 ga. cold rolled steel
Box Return Frame	16 ga. cold rolled steel, 2 1/2" deep frame
Hinge	180° full length piano hinge
Latch	Self latching lock with key and knurled knob
Automatic Door Closer	Standard on all doors
Inside Release Latch	Standard on all doors
Finish	White powder coat paintable finish
Options (at extra cost)	<ul style="list-style-type: none"> • Mortise lock preparation • Stainless steel #304 and #316 (#4 satin finish) • Masonry anchor straps • Custom sizes available

Note: WBFR BASIC access doors are for vertical applications only as code allows and no temperature rise is required.

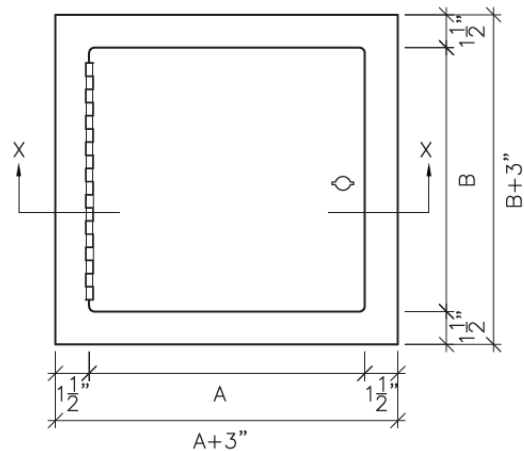

Elevation

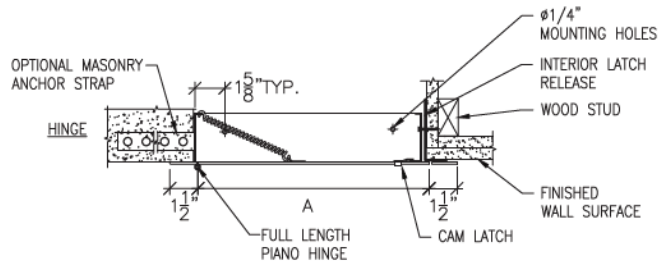

Section Detail

Model No.	A x B Door Size	Slam Latch	Shipping Weight (lbs) Steel/Stainless
WBFRB-88	8"x8"	1	6
WBFRB-1010	10"x10"	1	9
WBFRB-1212	12"x12"	1	11
WBFRB-1414	14"x14"	1	14
WBFRB-1616	16"x16"	1	17
WBFRB-1818	18"x18"	1	21
WBFRB-2020	20"x20"	1	24
WBFRB-2222	22"x22"	1	28
WBFRB-2230	22"x30"	2	29
WBFRB-2236	22"x36"	2	30
WBFRB-2424	24"x24"	1	26
WBFRB-2430	24"x30"	2	43
WBFRB-2436	24"x36"	2	38
WBFRB-3030	30"x30"	2	50

Rough wall opening = door size + 1/4"

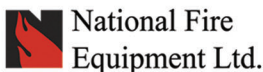

TORONTO: (905) 761-6355
Toll Free: (800) 267-8508
OTTAWA: (613) 723-6071

VANCOUVER: (604) 420-1131
Toll Free: (800)-667-2138
BURNABY: (604)-299-4498

EDMONTON: (780) 455-3870
Toll Free: (888)-891-1008
CALGARY: (403) 236-5661

MONCTON: (506) 859-7277
Toll Free: (877) 816-3473
MISSISSAUGA: (905) 565-1385

www.nationalfire.com



National Fire Equipment Ltd.

WBFR STANDARD DRYWALL FIRE RATED ACCESS DOOR & WBFR STANDARD PLASTER FIRE RATED ACCESS DOOR



Door and Trim	18 ga. cold rolled steel
Box Return Frame	16 ga. cold rolled steel, 1" wide perforated flange of 24 ga. galvanized drywall bead
Insulation	2" thick mineral wool contained within door cavity
Hinge	Fully concealed rod hinge. Allows opening to 170°.
Latch	Self-latching direct action latch, opposite hinge. Accepts both key and knurled knob, included with each door.

Automatic Panel Closer	Standard on all doors
Inside Panel Release	Standard on all doors
Finish	White powder coat paintable finish
Masonry Anchor Straps	Standard on all doors
Options (at extra cost)	<ul style="list-style-type: none"> Mortise lock preparation Ultra lock with key (code 151) Stainless steel #304 and #316 (#4 satin finish) Pemko smoke seal gasketing Custom sizes available
Ceiling Installation	To comply with current fire regulations, largest size acceptable is 24" x 36"

Model No.	A x B Door Size	Slam Catch	Hinges	Shipping Weight (lbs) Steel/Stainless
WBFRDW-1212	12"x12"	1	1	12
WBFRDW-1414	14"x14"	1	1	15
WBFRDW-1616	16"x16"	1	1	18
WBFRDW-1818	18"x18"	1	1	21
WBFRDW-2424	24"x24"	1	1	32
WBFRDW-2436	24"x36"	2	1	46

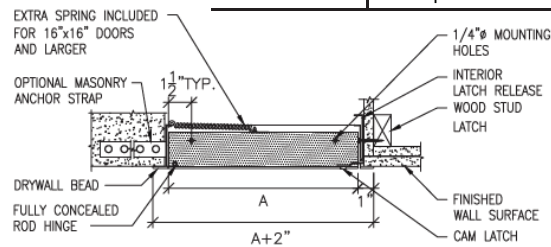

Rough wall opening = door size + 1/4"



Door and Trim	18 ga. cold rolled steel
Box Return Frame	16 ga. cold rolled steel, 3" wide perforated plaster flange of 24 ga. galvanized material. Space from the plaster mesh flange to the 1/4" safety edge of the door will accommodate 1" of plaster mud.
Insulation	2" thick mineral wool contained within door cavity
Hinge	Fully concealed rod hinge. Allows opening to 170°.
Latch	Self-latching direct action latch, opposite hinge. Accepts both key and knurled knob, included with each door.

Automatic Panel Closer	Standard on all doors
Inside Panel Release	Standard on all doors
Finish	White powder coat paintable finish
Masonry Anchor Straps	Standard on all doors
Options (at extra cost)	<ul style="list-style-type: none"> Mortise lock preparation Ultra lock with key (code 151) Stainless steel #304 and #316 (#4 satin finish) Pemko smoke seal gasketing Custom sizes available
Ceiling Installation	To comply with current fire regulations, largest size acceptable is 24" x 36"

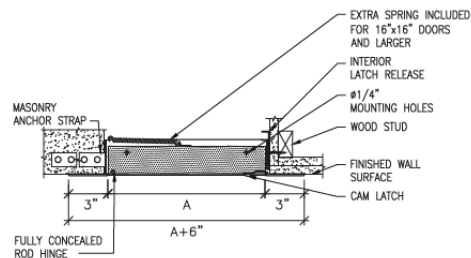

Rough wall opening = door size + 1/4"

Both WBFR Standard Plaster and Drywall Access Doors feature a tape-in flange that allows for a trimless appearance to eliminate visual distraction without compromising the fire rating. They are designed for both wall and ceiling applications. This door has an Underwriters Laboratories (UL and ULC), 1-1/2 hour "B" label, with a maximum temperature rise of 250 degrees Celsius after 30 minutes for vertical wall installations. File# R10364. Warnock Hersey International; Pittsburgh, CA 1 hour rating for combustible floor/ceiling applications. Report.# WHI-495-PSH-0191.

Warnock Hersey International, Pittsburgh, CA 3 Hour. rating for non-combustible floor/ceiling assembly, Report# WHI-495-PSH-0192. These doors may be used in a 2-hour fire rated wall assembly. For fire rated ceilings, this door has been approved by Warnock Hersey International for 3 hours (*max. size to 24" x 36"). Note: For fire-rated ceiling access doors, on size 16" x 16" and larger, extra spring supplied with door must be attached from back of door pan to framing or floor above. In horizontal (ceiling) applications door has self-assisted closing.

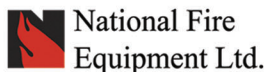

TORONTO: (905) 761-6355
Toll Free: (800) 267-8508
OTTAWA: (613) 723-6071

VANCOUVER: (604) 420-1131
Toll Free: (800)-667-2138
BURNABY: (604)-299-4498

EDMONTON: (780) 455-3870
Toll Free: (888)-891-1008
CALGARY: (403) 236-5661

MONCTON: (506) 859-7277
Toll Free: (877) 816-3473
MISSISSAUGA: (905) 565-1385

www.nationalfire.com



National Fire Equipment Ltd.

WBDW DRYWALL ACCESS DOOR & WBRDW RECESSED DRYWALL ACCESS DOOR



Door and Trim	16 ga. cold rolled steel door with 1" drywall bead and 24 ga. galvanized steel trim for mounting purposes
Frame	16 ga. cold rolled steel.
Hinge	Fully-concealed off-set hinge up to and including 24"x24". Number of hinges varies with size of the door and will be placed on long side of door unless otherwise specified. Doors larger than 24"x24" have full length piano hinge.

Latch	Flush, stainless steel cam operated with screwdriver. Latches are positioned opposite hinge as well as top and bottom on larger sizes.
Finish	White powder coat paintable finish
Options (at extra cost)	<ul style="list-style-type: none"> • Key Cylinder Lock with key (code 151) • Air-tight Neoprene Gasketing • Stainless Steel #304 or #316 (#4 satin finish)

The WBDW Drywall Access Door has the same quality features as the WBGD Premium with a tape-in drywall flange. This is designed to eliminate visual distraction, by allowing drywall cement to be applied to cover the flange at the time of installation.

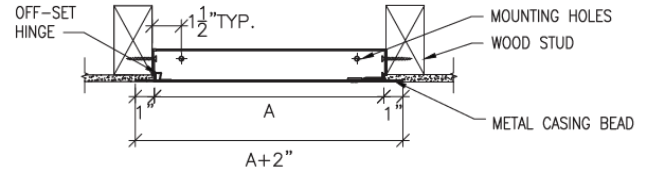

Model No.	A x B Door Size	Hinges	Cam Latch	Shipping Weight (lbs) Steel/Stainless
WBDW-88	8"x8"	1	1	3
WBDW-1010	10"x10"	1	1	5
WBDW-1212	12"x12"	1	3	7
WBDW-1224	12"x24"	3	2	12
WBDW-1414	14"x14"	2	3	9
WBDW-1616	16"x16"	2	3	11
WBDW-1818	18"x18"	2	3	12
WBDW-2222	22"x22"	3	4	18

Model No.	A x B Door Size	Hinges	Cam Latch	Shipping Weight (lbs) Steel/Stainless
WBDW-2230	22"x30"	PH	4	24
WBDW-2236	22"x36"	PH	5	27
WBDW-2424	24"x24"	3	4	20
WBDW-2436	24"x36"	PH	5	27
WBDW-2448	24"x48"	PH	6	37
WBDW-3030	30"x30"	PH	6	29
WBDW-3036	30"x36"	PH	7	31
WBDW-3636	36"x36"	PH	9	42

Rough wall opening = door size + 1/4"

PH = Full length piano hinge



Door and Trim	16 ga. cold rolled steel. Door is recessed 5/8" to accept drywall.
Frame	16 ga. cold rolled steel. 1" wide perforated 24 ga. galvanized steel for mounting purposes.
Hinge	Fully concealed rod type hinge, will be placed on long side of door unless otherwise requested.

Latch	Flush, stainless steel cam operated with screwdriver. Latches are positioned opposite hinge as well as top and bottom on larger sizes.
Finish	White powder coat paintable finish
Options (at extra cost)	<ul style="list-style-type: none"> • Medium barrel cylinder lock • Drywall with door • Air-tight Neoprene Gasketing

The WBRDW Recessed Drywall Access Door features a 5/8" recessed pan that gives the option of installing a matching piece of drywall into the door panel, keeping the continuity of the visual area. The outdoor frame has a tape-in flange so that the unit may be cemented in place at the time of installation.

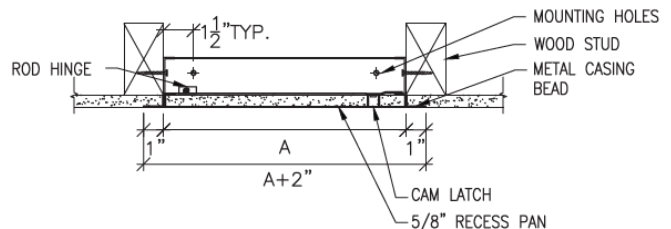

Model No.	A x B Door Size	Hinges	Cam Latch	Shipping Weight (lbs) Steel/Stainless
WBRDW-1212	12"x12"	1	1	6
WBRDW-1224	12"x24"	1	4	13
WBRDW-1616	16"x16"	1	3	12
WBRDW-1818	18"x18"	1	3	13
WBRDW-2424	24"x24"	1	4	21
WBRDW-2436	24"x36"	1	5	32

Rough wall opening = door size + 1/4"

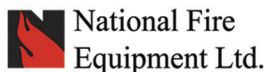

TORONTO: (905) 761-6355
Toll Free: (800) 267-8508
OTTAWA: (613) 723-6071

VANCOUVER: (604) 420-1131
Toll Free: (800)-667-2138
BURNABY: (604)-299-4498

EDMONTON: (780) 455-3870
Toll Free: (888)-891-1008
CALGARY: (403) 236-5661

MONCTON: (506) 859-7277
Toll Free: (877) 816-3473
MISSISSAUGA: (905) 565-1385

www.nationalfire.com



National Fire Equipment Ltd.

WBPL PLASTER ACCESS DOOR & WBAP ACOUSTICAL PLASTER ACCESS DOOR

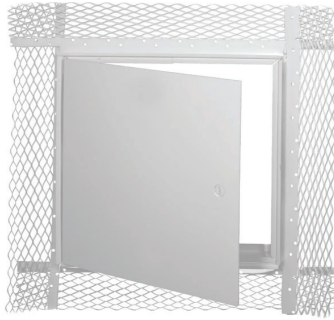

Door and Trim	16 ga. cold rolled steel
Box Return Frame	16 ga. steel. 3" wide plaster mesh flange of 24 ga. galvanized material. Space from the expanded flange to the 1/4" safety edge of the door will accommodate 1" of plaster.
Hinge	Fully-concealed off-set hinge. Number of hinges varies with size of door and will be placed on long side of door unless otherwise requested. Doors larger than 24"x24" have full length piano hinge.

Latch	Flush, stainless steel cam operated with screwdriver. Latches are positioned opposite hinge as well as top and bottom on larger sizes.
Finish	White powder coat paintable finish
Options (at extra cost)	<ul style="list-style-type: none"> • Key Cylinder Lock with key (code 151) • Air-tight Neoprene Gasketing • Stainless Steel #304 or #316 (#4 satin finish)

The WBPL Plaster Access Door is a flush door designed for wall and ceiling application, featuring a tape-in plaster bead. This allows for plaster mud to be applied to the flange concealing it. The 1/4" safety edge gives the door a strong frame and prevents the plaster from being chipped under normal use.

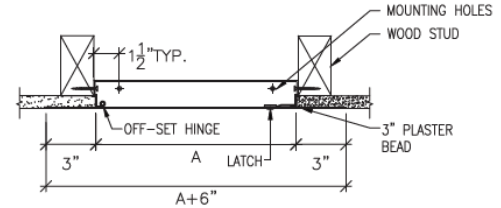

Model No.	A x B Door Size	Hinges	Cam Latch	Shipping Weight (lbs) Steel/Stainless
WBPL-88	8"x8"	1	1	4
WBPL-812	8"x12"	2	1	6
WBPL-1010	10"x10"	1	1	5
WBPL-1212	12"x12"	2	1	7
WBPL-1216	12"x16"	2	3	8
WBPL-1218	12"x18"	2	3	8
WBPL-1414	14"x14"	2	3	10
WBPL-1616	16"x16"	2	3	12

Model No.	A x B Door Size	Hinges	Cam Latch	Shipping Weight (lbs) Steel/Stainless
WBPL-1620	16"x20"	2	3	15
WBPL-1818	18"x18"	2	3	13
WBPL-2024	20"x24"	3	4	17
WBPL-2222	22"x22"	3	4	19
WBPL-2424	24"x24"	3	4	20
WBPL-2430	24"x30"	PH	4	24
WBPL-2436	24"x36"	PH	5	30

Rough wall opening = door size + 1/4"

PH = Full length piano hinge



Door and Trim	16 ga. cold rolled steel. Door is recessed 5/8" and lined with expanded metal lath
Box Return Frame	16 ga. steel with 24 ga. plaster mesh galvanized casing bead and expanded metal lath surrounding door
Hinge	Full length piano hinge opens 180°, will be placed on long side of door unless otherwise requested

Latch	Flush, stainless steel cam operated with screwdriver
Finish	White powder coat paintable finish
Options (at extra cost)	Medium barrel cylinder lock

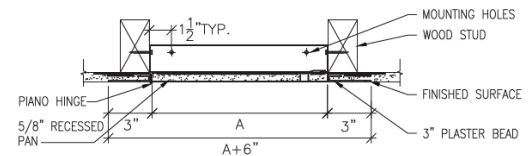

The WBAP Acoustical Plaster Access Door is a precision door that provides a virtually concealed installation, keeping acoustical surfaces intact while contributing to sound control and better appearance. Door panels are recessed to receive plaster up to 5/8" thick. Plaster covering the door finishes flush with the surrounding field, leaving only the narrow frame edges exposed. The metal sides of the recessed door panel prevent damage to the edges of the plaster. This door operates on a continuous stainless steel piano hinge, located at the outside edge so that the door may be opened fully to 180 degrees.

Model No.	A x B Door Size	Hinges	Cam Latch	Shipping Weight (lbs) Steel/Stainless
WBAP-1212	12"x12"	1	1	10
WBAP-1224	12"x24"	1	2	13
WBAP-1818	18"x18"	1	3	15
WBAP-2424	24"x24"	1	4	28
WBAP-2436	24"x36"	1	5	37

Rough wall opening = door size + 1/4"

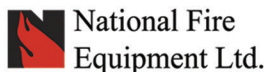

TORONTO: (905) 761-6355
Toll Free: (800) 267-8508

VANCOUVER: (604) 420-1131
Toll Free: (800)-667-2138

EDMONTON: (780) 455-3870
Toll Free: (888)-891-1008

MONCTON: (506) 859-7277
Toll Free: (877) 816-3473

OTTAWA: (613) 723-6071

BURNABY: (604)-299-4498

CALGARY: (403) 236-5661

MISSISSAUGA: (905) 565-1385

www.nationalfire.com



National Fire Equipment Ltd.

WBAT ACOUSTICAL TILE ACCESS DOOR & WBTBAR CEILING ACCESS DOOR



Door and Trim	16 ga. cold rolled steel. Door is recessed to accept up to 5/8" acoustical tile.
Frame	16 ga. cold rolled steel
Hinge	Continuous piano hinge opens 180 degrees, will be placed on long side of door unless otherwise requested.

Latch	Flush, stainless steel cam operated with screwdriver. Latches positioned opposite hinge as well as top and bottom on larger sizes.
Finish	White powder coat paintable finish
Options (at extra cost)	Medium Barrel Cylinder Lock

The WBAT Acoustical Tile Access Door is a precision ceiling door that provides a virtually concealed installation, keeping acoustical surfaces intact while contributing to sound control and better appearance. The door is recessed to accept up to 5/8" thick acoustical tile. Each door comes complete with grommets.

Model No.	A x B Door Size	Hinges	Cam Latch	Shipping Weight (lbs)
WBAT-1212	12"x12"	1	1	8
WBAT-1224	12"x24"	1	2	13
WBAT-1818	18"x18"	1	3	15
WBAT-2424	24"x24"	1	3	25
WBAT-2436	24"x36"	1	5	33

Rough wall opening = door size + 1/4"

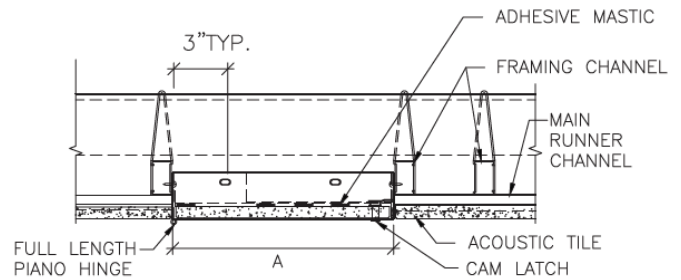

Door and Trim	.063 aluminum
Hinge	Continuous piano hinge
Latches	Flush stainless steel cam
Finish	Powder coat white
Options (at extra cost)	Key Cylinder Lock with key (code 151)

The WB-T-Bar Ceiling Access Door is a light weight aluminum door that simply drops into a t-bar ceiling with ease. Included with each door are mounting screws for a safe and secure ceiling installation.

Model No.	A x B Door Size	Ceiling Opening	Cam Latch	Shipping Weight (lbs)
WBTBAR-2424	24"x24"	23 3/4" x 23 3/4"	4	6
WBTBAR-2448	24"x48"	23 3/4" x 47 3/4"	6	11

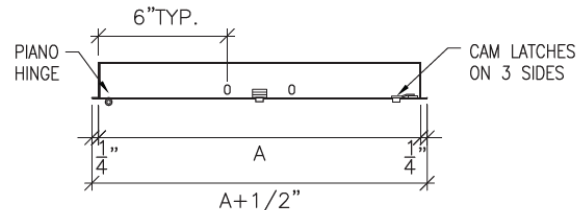



National Fire Equipment Ltd.

WBMS MEDIUM SECURITY ACCESS DOOR & WBHS HIGH SECURITY ACCESS DOOR



Door and Trim	12 ga. cold rolled steel
Frame	16 ga. cold rolled steel
Hinge	Full length piano hinge
Lock	1/4-20 tamper proof screw assemblies
Finish	White powder coat paintable finish

Options (at extra cost)	<ul style="list-style-type: none"> Stainless steel #304 and #316 (#4 satin finish) Mortise lock preparation with or without cylinder Air-tight Neoprene Gasketing Cylinder lock with key (code 151)
-------------------------	-----------------------------------------------------------------------------------------------------------------------------------------------------------------------------------------------------------------------------------------------

The WBMS Medium Security Access Door is the door of choice when it is necessary to assure security under institutional conditions. Most detention buildings and mental health facilities require access to vital services in or behind walls, shafts and stairwells without jeopardizing security. The door can be customized to accommodate any mortise lock specified.

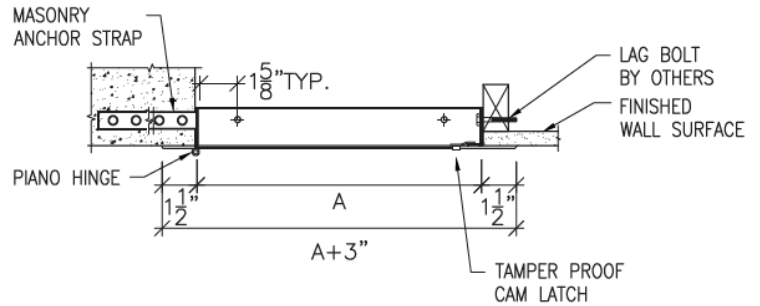

Model No.	A x B Door Size	Full Length Semi-Concealed Piano Hinge	Tamper Proof Screw Locks	Shipping Weight (lbs)
WBMS-1212	12"x12"	1	1	22
WBMS-1616	16"x16"	1	3	31
WBMS-1818	18"x18"	1	3	36

Model No.	A x B Door Size	Full Length Semi-Concealed Piano Hinge	Tamper Proof Screw Locks	Shipping Weight (lbs)
WBMS-2424	24"x24"	1	4	52
WBMS-2436	24"x36"	1	5	73
WBMS-3636	36"x36"	1	9	103

Rough wall opening = door size + 1/4"



Door and Trim	10 ga. cold rolled steel
Frame	2"x 2"x 3/16" angle
Hinge	Heavy duty type butt hinges welded to surround and door
Lock	Prepped for detention lock

Finish	White powder coat paintable finish
Options (at extra cost)	<ul style="list-style-type: none"> Stainless steel #304 and #316 (#4 satin finish) Custom sizes Detention lock and paracentric key

The WBHS High Security Access Door is designed for installation where maximum security is mandatory. This door comes prepped for a detention lock for controlled access, which is sold separately. It can be prepped for custom mortise locks and requirements.

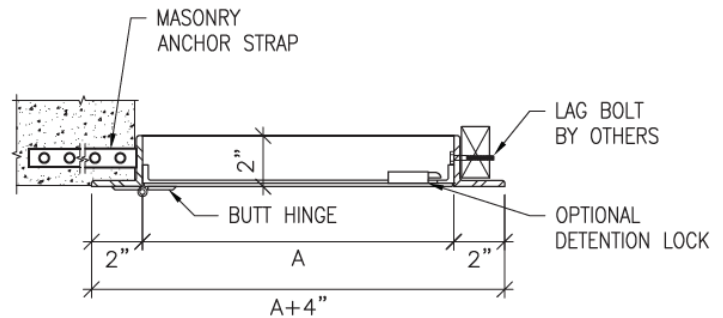

Model No.	A x B Door Size	Heavy Duty Detention Hinges	Shipping Weight (lbs) Steel/Stainless
WBHS-1212	12"x12"	2	46
WBHS-1616	16"x16"	2	56
WBHS-1818	18"x18"	2	62
WBHS-2424	24"x24"	2	82
WBHS-2436	24"x36"	3	134
WBHS-3636	36"x36"	3	140

Rough wall opening = door size + 3/4"

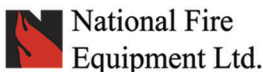

TORONTO: (905) 761-6355
Toll Free: (800) 267-8508
OTTAWA: (613) 723-6071

VANCOUVER: (604) 420-1131
Toll Free: (800)-667-2138
BURNABY: (604)-299-4498

EDMONTON: (780) 455-3870
Toll Free: (888)-891-1008
CALGARY: (403) 236-5661

MONCTON: (506) 859-7277
Toll Free: (877) 816-3473
MISSISSAUGA: (905) 565-1385

www.nationalfire.com



National Fire Equipment Ltd.

WBEXT EXTERIOR T HANDLE ACCESS DOOR & WBWTD WALK THROUGH ACCESS DOOR



Door and Trim	16 ga. satin coat, trim 1 3/4" wide.	Insulation	2" Layer AMVIC SilverBoard Ridge Foam Insulation with a R/O Value 10
Frame	Continuous stainless steel piano hinge. Allows opening to 180°	Gasket	Open celled microcellular polyurethane on inside of door and closed cell neoprene sponge SC42 W/PSA striping gasketing on the back of the door
Latch	Chrome-plated zinc "T" type handle with pivot rod 3 point catch. Opens from the outside only.	Application	For exterior purposes, weather resistive
Finish	Powder coat white	Options	Powder coat grey ASA61

The WBEXT Exterior T Handle Access Door is constructed of galvanized steel and is insulated. It features two types of gasketing: weather resistive open cell microcellular polyurethane gasketing and closed cell neoprene sponge SC42 W/PSA striping gasketing on the inside for outdoor applications (certain saltwater areas might not be compatible).

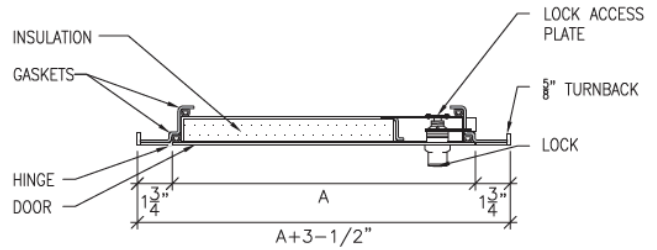

Model No.	A x B Door Size	Shipping Weight (lbs)
WBEXT-1212	12"x12"	27
WBEXT-1414	14"x14"	32
WBEXT-1616	16"x16"	36
WBEXT-1818	18"x18"	41
WBEXT-2230	22"x30"	45
WBEXT-2236	22"x36"	50

Model No.	A x B Door Size	Shipping Weight (lbs)
WBEXT-2424	24"x24"	55
WBEXT-2436	24"x36"	67
WBEXT-3030	30"x30"	75
WBEXT-3036	30"x36"	79
WBEXT-3636	36"x36"	90

Rough wall opening = door size + 1/4"



Door and Trim	22 ga. satin coat
Trim	16 ga. satin coat
Return Frame	16 ga. satin coat, 1 3/4" deep
Hinge	Full-length piano hinge
Latch	L-Handle operable from both sides. Doors higher than 48" come with 3 handles

Insulation	1" thick AMVIC SilverBoard Ridge Foam Insulation
Gasket	Neoprene gasketing on all 4 sides of door
Finish	Powder coat aluminum finish
Options (at extra cost)	<ul style="list-style-type: none"> Stainless steel #304 and #316 (#4 satin finish) Extra latches Custom sizes available

The WBWTD Walk Through Access Door is an insulated walk through door. It provides easy access to interior duct work and air handling equipment. It is constructed with galvanized steel to ensure durability. It comes complete with neoprene gasketing, insulation, full length piano hinge and a T-Handle locking latch that is operable from both sides.

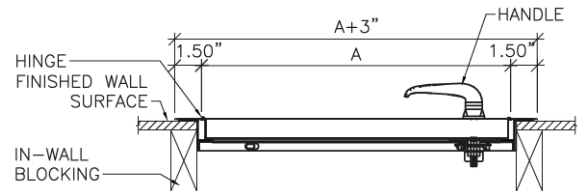

Model No.	A x B Door Size	Hinge	Latch	Shipping Weight (lbs)
WBWTD-2436	24"x36"	1	2	32
WBWTD-2448	24"x48"	1	3	42
WBWTD-2460	24"x60"	1	3	52
WBWTD-2472	24"x72"	1	3	62

Model No.	A x B Door Size	Hinge	Latch	Shipping Weight (lbs)
WBWTD-3036	30"x36"	1	2	39
WBWTD-3048	30"x48"	1	3	52
WBWTD-3060	30"x60"	1	3	65
WBWTD-3072	30"x72"	1	3	78

Rough wall opening = door size + 1/2"

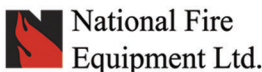

TORONTO: (905) 761-6355
Toll Free: (800) 267-8508
OTTAWA: (613) 723-6071

VANCOUVER: (604) 420-1131
Toll Free: (800)-667-2138
BURNABY: (604)-299-4498

EDMONTON: (780) 455-3870
Toll Free: (888)-891-1008
CALGARY: (403) 236-5661

MONCTON: (506) 859-7277
Toll Free: (877) 816-3473
MISSISSAUGA: (905) 565-1385

www.nationalfire.com



National Fire Equipment Ltd.

WBMAP PLASTIC MULTI-FUNCTIONAL ACCESS DOOR & WBGYP GYPSUM PANEL ACCESS DOOR



Door and Frame	High impact ABS plastic with UV stabilizers. Pivot hinged door panel with removable feature.
Lock	Door is locked to return frame with snap friction catch

Finish	White textured finish
Installation	Adhesive caulking recommended
Packaging	Individually wrapped. Sold in cases.

The WBMAP Plastic Multi-Functional Access Door is an economical choice that allows easy access to plumbing, electrical wiring and other utility applications behind walls and ceilings. The door is constructed from high impact ABS plastic and has a textured finish.

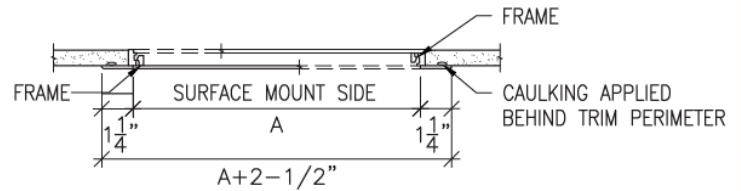

Model No.	A x B Door Size	Frame to Outer Flange	Shipping Weight Per Case (lbs)
WBMAP-46	3 3/4" x 5 3/4"	5" x 7"	3
WBMAP-69	5 3/4" x 8 3/4"	7 3/4" x 10 3/4"	6
WBMAP-88	7 3/4" x 7 3/4"	9 3/4" x 9 3/4"	7

Model No.	A x B Door Size	Frame to Outer Flange	Shipping Weight Per Case (lbs)
WBMAP-1212	11 1/2" x 11 1/2"	14" x 14"	13
WBMAP-1414	13 3/4" x 13 3/4"	16" x 16"	18
WBMAP-2222	21 3/4" x 21 3/4"	24 3/4" x 24 3/4"	23



Door and Frame	Glass Fiber Reinforced Gypsum/Cement
Lock	Glass Fiber Reinforced Gypsum/Cement
Finish	Unpainted Natural Grey Gypsum

Options (at extra cost)	<ul style="list-style-type: none"> • Neoprene Gasket • Slotted Cam Latch • Keyed Cam Lock • Concealed Hinge Design • Custom Sizes Available
-------------------------	------------------------------------------------------------------------------------------------------------------------------------------------------------------------------------------------

The WBGYP Gypsum Panel Access Door is a state-of-the-art lightweight gypsum panel manufactured from inorganic material and 70% postconsumer recycled glass, using a patented composition. It is designed to blend seamlessly into walls and ceilings. Lightweight and easily textured, the panels can be used in both new or retrofit construction across unlimited applications. It is available in a pop-out or concealed hinged design with square or radius corners. It is moisture-resistant with zero mold and fungus growth.

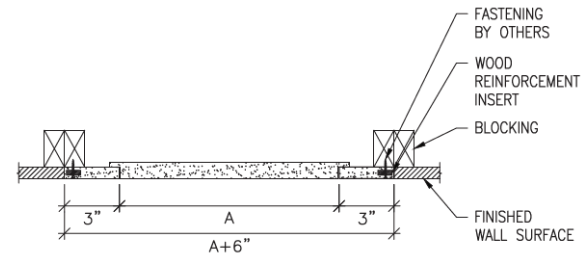

Model No.	A x B Door Size	Shipping Weight (lbs)
WBGYP-99	9"x9"	5.6
WBGYP-1212	12"x12"	7.6
WBGYP-1616	16"x16"	10.7
WBGYP-1818	18"x18"	18.2
WBGYP-2424	24"x24"	24.9
WBGYP-3030	30"x30"	32.7



Rough wall opening = door size + 6"



National Fire Equipment Ltd.

WBNTG TRIMLESS GYPSUM ACCESS DOOR



Door and Trim	.080 aluminum extrusion with 5/8" drywall inserted into door panel and brush gasket
Frame	.080 aluminum extrusion (1/2" & 5/8" available)

Hinge	Pivot Type - allows for door removal
Latch	Push to open
Finish	Mill Finish

The WBNTG Trimless Gypsum Access Door is a high quality access door designed to be as invisible as possible while maintaining an architecturally pleasing appearance. The door is supplied with moisture resistant 5/8" drywall and recessed to allow for finishing of wall or ceiling surface. A safety chain is installed on the door and frame. Brush gasket minimizes debris and air infiltration.

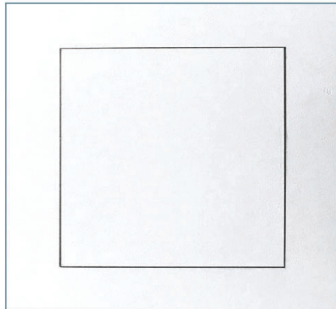
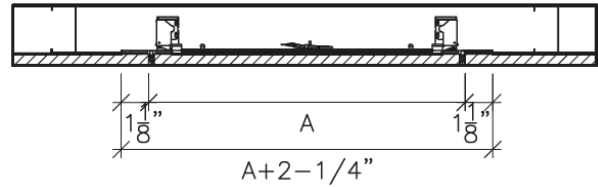

Ceiling view



Model No.	Frame Size (w x h)	Weight (lbs) w/o gypsum
WBNTG-88	8"x8"	1
WBNTG-1212	12"x12"	2
WBNTG-1616	16"x16"	5
WBNTG-1818	16"x16"	6
WBNTG-2020	20"x20"	8
WBNTG-2424	24"x24"	12
WBNTG-3636	36"x36"	18

*Allow 1/2" around frame for installation



National Fire Equipment Ltd.

ACCESSORIES



WB 500
MEDIUM
PADDLE LATCH

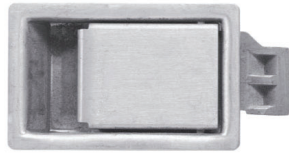

WB 501
SMALL
PADDLE LATCH



WB 502
KEY LATCH FOR FR STANDARD
AND FR BASIC DOOR



WB 503
KNURL KNOB FOR FR STANDARD
AND FR BASIC DOOR



WB 504
STANDARD CYLINDER LOCK
(151 KEYCODE)



WB 505
MEDIUM BARREL
CYLINDER LOCK



WB 506
TAMPER PROOF TORX AND
SNAKE EYE SCREWS



WB 507
E SERIES MORTISE BODY
WITH CHANGEABLE CORE



WB 508
MORTISE
CYLINDER CORE



WB 509
HEAVY DUTY
DETENTION LOCK



WB 510
T TYPE
CABINET HANDLE



WB 511
L TYPE CABINET HANDLE
(151 KEYCODE)



WB 512
ULTRA KEY LATCH
(151 KEYCODE)