



National Fire Equipment Ltd.

WB-ABS HEAVY DUTY CABINETS

Ideal for use in outdoor environments. The WB-ABS cabinet has anti-UV properties and a neoprene gasket for a water resistant seal. 2x latches with built in hasps for padlock (not incl.) if required. 2x Plexi windows ensures good visibility of equipment and overall door strength.



Parts

- 1 Door
- 2 Acrylic Viewing Panels
- 3-5 Woven Nylon Restraining Strap & Tension Buckle
- 6 Tub
- 7-10 Buckle (x2)
- 11 Neoprene Gasket Seal
- 12 Base Plate

Construction Specifications:

- 2.5MM ABS Construction
- Black Tub/ Red Door
- Neoprene Gasket
- 2x Snap Closures
- 2x Clear Acrylic Viewing Panels



Model	Description	Measurements (mm)						
		A	B	C	D	E	F	G
WB-ABS1	1x 20lb Dry Chemical Fire Extinguisher	830	750	260	215	320	280	200
WB-ABS2	2x 20lb Dry Chemical Fire Extinguishers or 75ft 1 1/2" Rack Hose w/ 1 1/2" Angle Valve	710	620	270	200	580	530	430

Section Detail (mm):

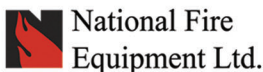
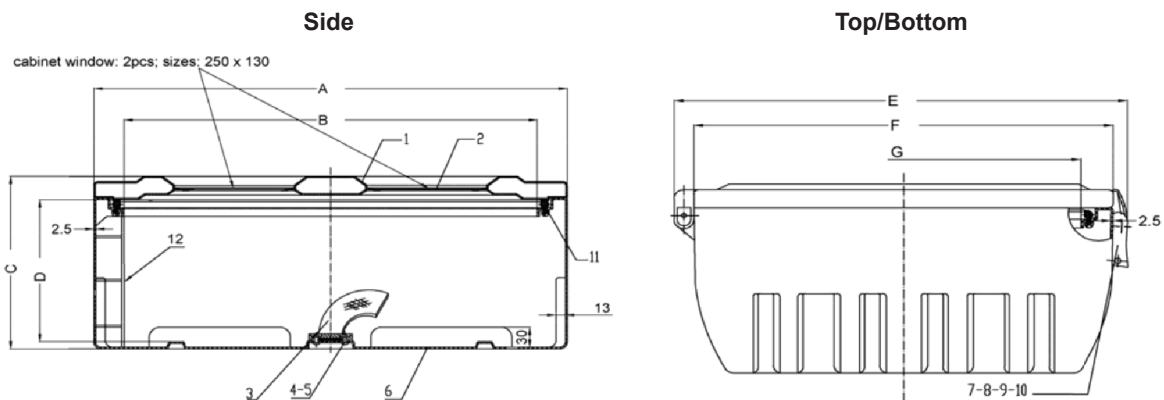

TORONTO: (905) 761-6355
Toll Free: (800) 267-8508
OTTAWA: (613) 723-6071

VANCOUVER: (604) 420-1131
Toll Free: (800)-667-2138
BURNABY: (604)-299-4498

EDMONTON: (780) 455-3870
Toll Free: (888)-891-1008
CALGARY: (403) 236-5661

MONCTON: (506) 859-7277
Toll Free: (877) 816-3473
MISSISSAUGA: (905) 565-1385