



National Fire Equipment Ltd.

VALVE & EXTINGUISHER CABINET

14" X 38" X 8" 10LB EXTINGUISHER + VALVE CABINET

STANDARD CONSTRUCTION FEATURES:

- 1/2" Turnback on trim (recessed)
- Full glass front with paddle latch
- Full length piano hinge
- Grey or white powdered coated finish
- Accommodates 10lb dry chemical extinguisher & 1.5" or 2.5" valve

OPTIONAL FEATURES:

- Break glass door and lock
- Cylinder lock
- Stainless steel door & trim (#4 finish, SOSS hinge & 3/4" turnback)
- Full metal front
- Neoprene weatherproof gasketing

RECESSED

Model: VECR-14388FGC

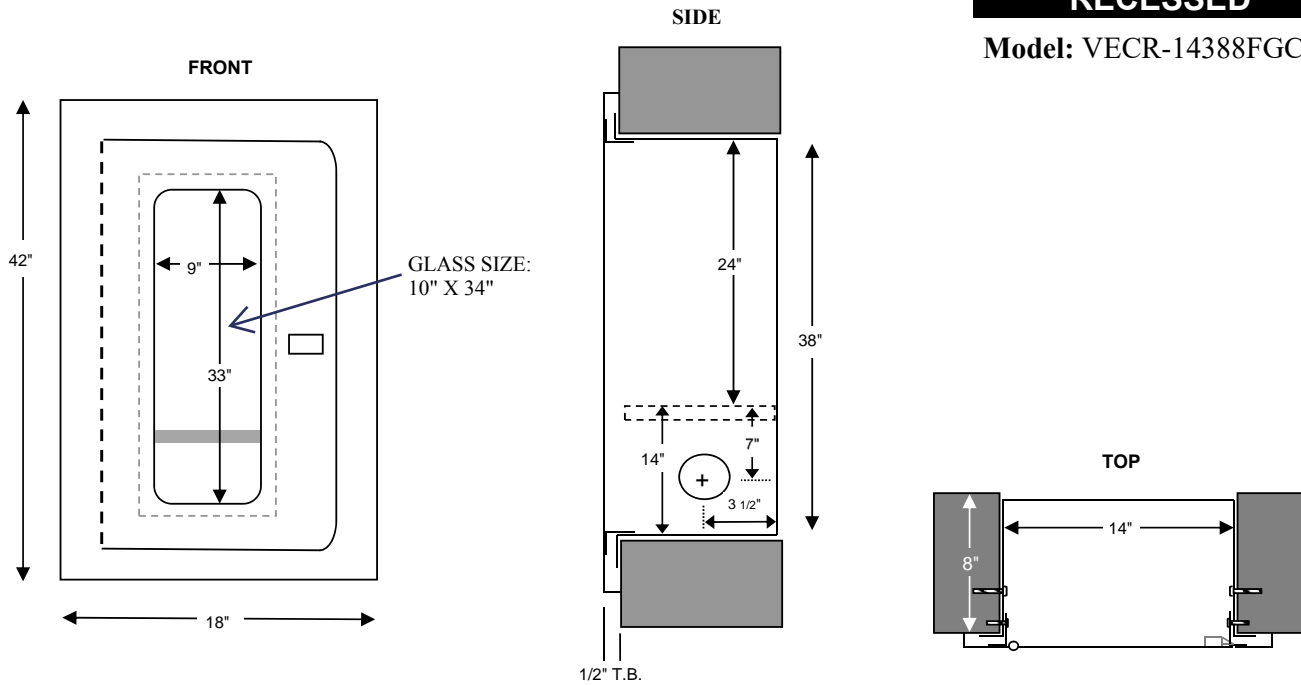

SURFACE

Model: VECS-14388FGC

