

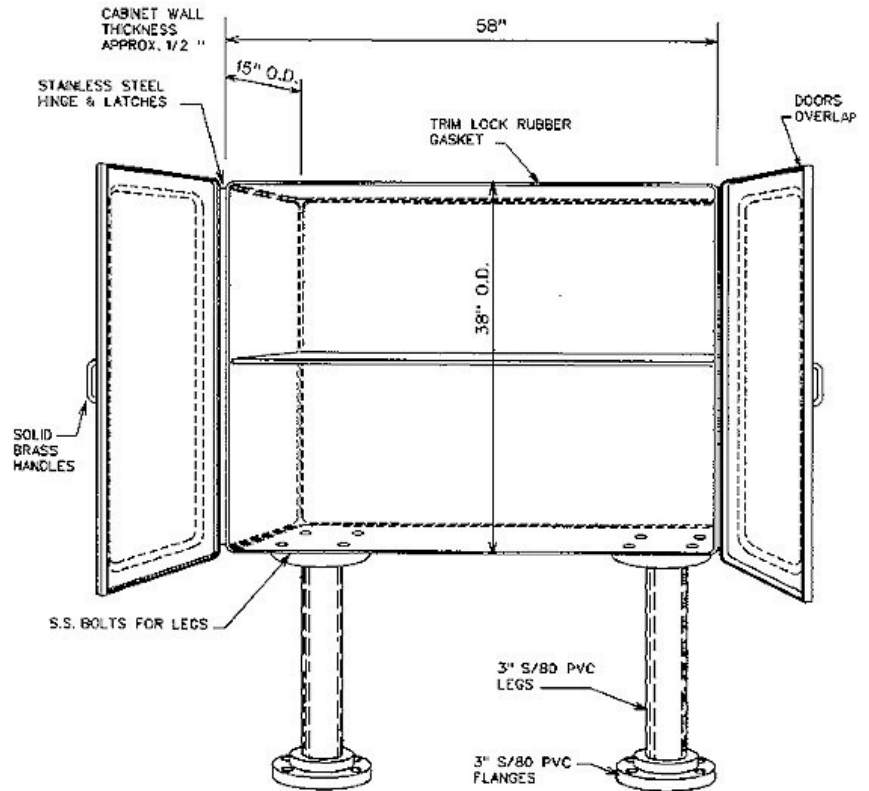

NATIONAL FIRE EQUIPMENT LTD.

SERVICE, SOLUTIONS, INNOVATION

MODEL FHC-10 FIBERGLASS HOSE STORAGE CABINET



Inside dimensions: 36.5" x 57" x 14.5"

Standard Features:

- Manufactured under USA Patent No. 41898.567
- Used by the USA & Canadian Coast Guard
- Solid brass grab handles
- Full length stainless steel hinges
- Stainless steel rivets and quick-opening latches
- Meets or exceeds NEMA 4X rating
- Standard classifications emblems
- Red standard colour choice
- Chemical resistant construction

Optional Features:

- Easy view acrylic window for verification of contents
- Lockable latches
- Fire retardant construction
- Custom design shelving
- Stainless steel grab handles
- Custom classification emblems
- PVC 3" legs
- Aluminum angle support 1.5" x 1.5" x .25"