



National Fire Equipment Ltd.

MEDIUM SECURITY FIRE EXTINGUISHER RECESSED CABINET

Model: 102RS-MED

8"w x 17"h x 5"d

STANDARD CONSTRUCTION FEATURES

- 1/2" Turnback on trim
- 12 ga. Full Metal Door & Trim, 14 ga. Tub
- White Powder Coat Paint Finish
- Accomadates 5lb Dry Chemical Fire Extinguisher
- * ABC-050WWD
- Cylinder Lock (Keyed alike)
- Full Length Piano Hinge

OPTIONS

- 304 or 316 Stainless Steel (#4 Satin Finish)
- S.S. cabinet equipped with SOSS Hinges
- Mortise Lock
- Die cut vinyl decals/lettering
- Grey and Red Powder Coat Paint Finish

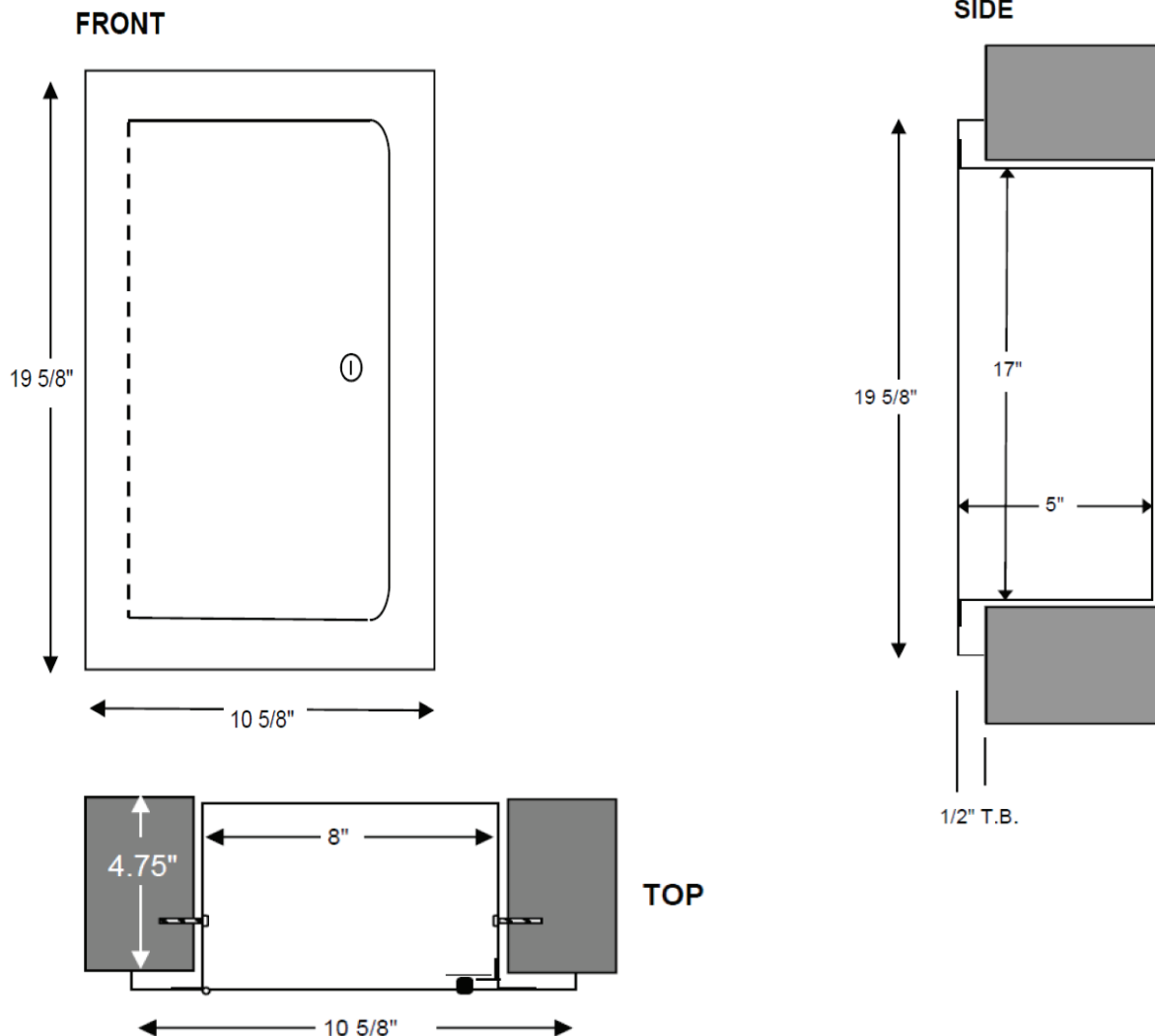

Rough opening should be 1/4" larger than Exterior Tub (H x W).
Minimum 4" Wall depth required



**National Fire
Equipment Ltd.**

TORONTO: (905) 761-6355
Toll Free: (800) 267-8508

OTTAWA: (613) 723-6071

VANCOUVER: (604) 420-1131
Toll Free: (800)-667-2138

BURNABY: (604)-299-4498

EDMONTON: (780) 455-3870
Toll Free: (888)-891-1008

CALGARY: (403) 236-5661

MONCTON: (506) 859-7277
Toll Free: (877) 816-3473

MISSISSAUGA: (905) 565-1385

www.nationalfire.com