



National Fire Equipment Ltd.

Knight® Recessed Fire Hose Cabinets



Recessed Cabinet Model Knight 200-2

Specifications:

Recessed cabinets shall be KNIGHT-____, ____"x____"x____" with 18 gauge (1.19mm) white powder coated steel tubs. 14 Gauge (2mm) white powder coated steel door & frame with hollow channel reinforcement. Front section to have 2" (51mm) adjustment to wall surface and complete with 1/2" (13mm) turn back frame. Complete with full-length semi-concealed piano hinges, Model SMSS flush stainless steel door latch, and full panel of 1/4" duolite glass. Stainless steel fronts to have (3) fully concealed "SOSS" hinges.

WARNING: Standard powder coated cabinets are not designed for outdoor applications. Depending on environment use epoxy coatings, galvanized, stainless steel or fiberglass materials. Contact our customers service representatives for assistance.

KNIGHT® RECESSED CABINETS

The standard in fire hose equipment storage. Designed and fabricated for strength, safety and durability using the best quality metal and finished with baked enamel. Frames are standard with 2" (51mm) adjustment. Doors rotate a full 180° and can be site adjusted for left or right door swing. All edges are ground and rounded for safety. Cabinets can also be modified for "semi-recessed" shallow wall installations.

ALL INTERIOR COMPONENTS ARE EXTRA AND MUST BE ORDERED SPERATELY

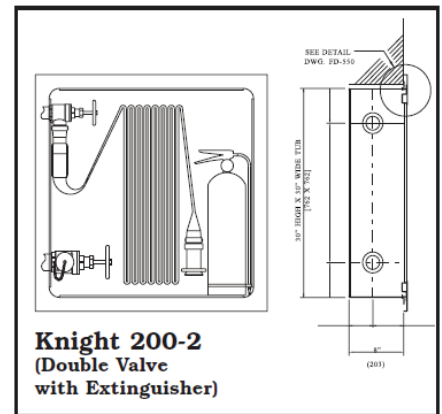
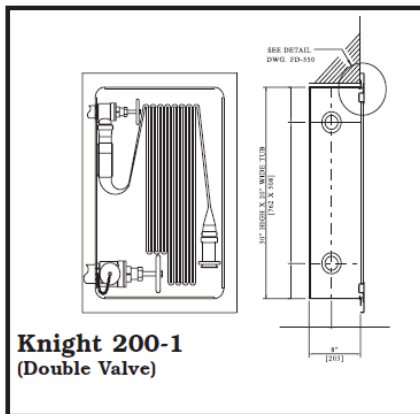
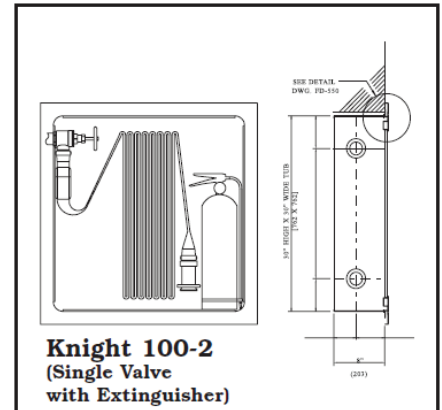
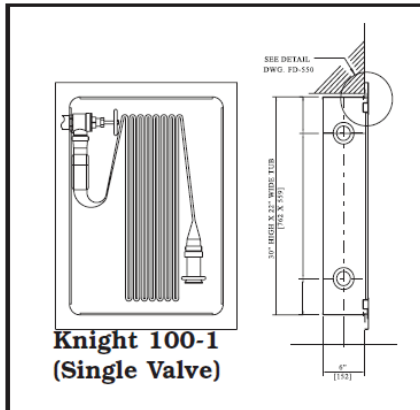

Model	Tub Dimensions	Mountain Type	Minimum Wall Depth	Fire Extinguisher Maximum	Valves
CK-1001	22" x 30" x 6" (559mm x 762mm x 152mm)	Recessed	6" (152mm)	No	1 1/2" Only
CK-1002-6	30" x 30" x 6" (762mm x 762mm x 152mm)	Recessed	6" (152mm)	10 lbs. Dry Chem.	1 1/2" Only
CK-1002	30" x 30" x 8" (762mm x 762mm x 203mm)	Recessed	8" (203mm)	20 lbs. Dry Chem.	1 1/2" Only
CK-2001	20" x 30" x 8" (508mm x 762mm x 203mm)	Recessed	8" (203mm)	No	1 1/2" & 2 1/2"
CK-2002	30" x 30" x 8" (762mm x 762mm x 203mm)	Recessed	8" (203mm)	10 lbs. Dry Chem.	1 1/2" & 2 1/2"

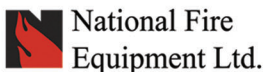

TORONTO: (905) 761-6355
Toll Free: (800) 267-8508
OTTAWA: (613) 723-6071

VANCOUVER: (604) 420-1131
Toll Free: (800)-667-2138
BURNABY: (604)-299-4498

EDMONTON: (780) 455-3870
Toll Free: (888)-891-1008
CALGARY: (403) 236-5661

MONCTON: (506) 859-7277
Toll Free: (877) 816-3473
MISSISSAUGA: (905) 565-1385

www.nationalfire.com