



## Sway Brace Seismic - Fig. 778 Bar Joist Beam Attachment

**Size Range:** Structural Steel: Minimum Thickness – 1/8" (FM), 3/16" (UL), Maximum Thickness – 3/4"

**Service Pipe:** 1" through 8"

**Material:** Ductile iron beam attachment, shear head bolts and hex head mounting bolt

**Finish:** Plain or Galvanized

**Service:** Used to rigidly brace piping systems subjected to sway and seismic disturbances. Structural attachment component of Anvil's 700 series sway brace assembly. Recommended for use under roof installations with bar joist construction or for attachment to the top or bottom flange of structural steel beams. Can be utilized as a structural connection for either a lateral brace or a longitudinal brace.

**Approvals:** UL and ULC Listed (UL 203A:2009), and FM Approved (FM 1950:2010). Complies with seismic bracing requirements of NFPA-13.

**Features:**

- Permits secure quick connection to structural members where drilling and/or welding of brace connection is not allowed or is not easily accomplished
- Shear head bolt design ensures that the proper installation torque is accomplished for a tight non-slip fit to the structural member.
- Bar joist beam attachment is designed for concentric loadings of seismic connections and fasteners.

**Installation Instructions:**

1. Place Fig. 778 on the structural steel beam. Steel member must fully engage throat of Fig. 778.
2. Tighten the set bolts equally and alternately until bolt heads shear off. The use of an impact wrench is not recommended.
3. Attach 700 Series Anvil Brace Fittings using the included 1/2" mounting bolt and adjust orientation as needed for proper brace angle.

**Ordering:** Specify figure number, name and finish.

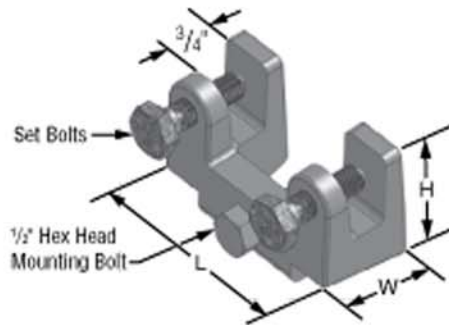

FIG. 778: WEIGHT (LBS) • DIMENSIONS (IN)			
H	L	W	Weight
2.37	3.93	1.92	2.14

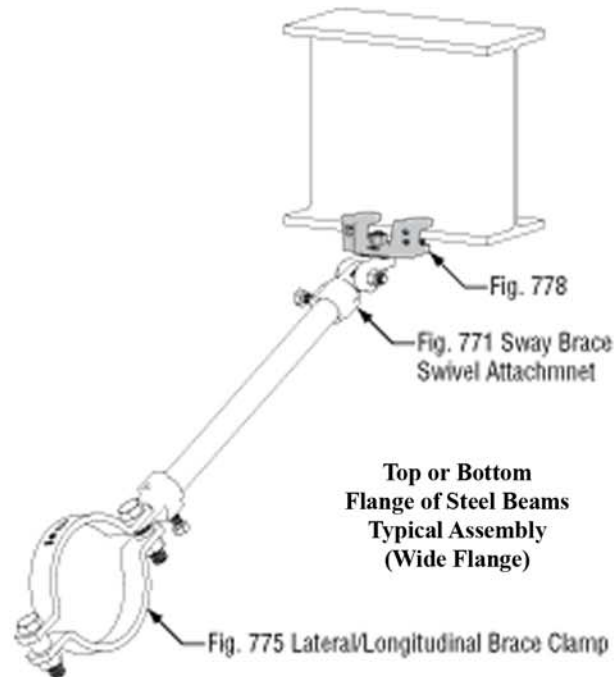
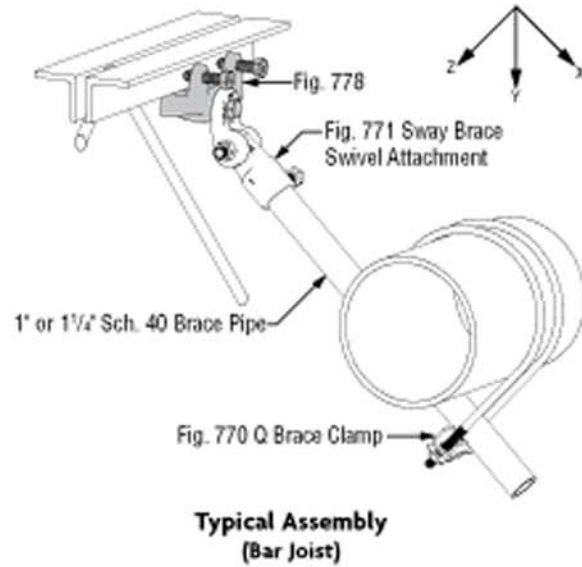
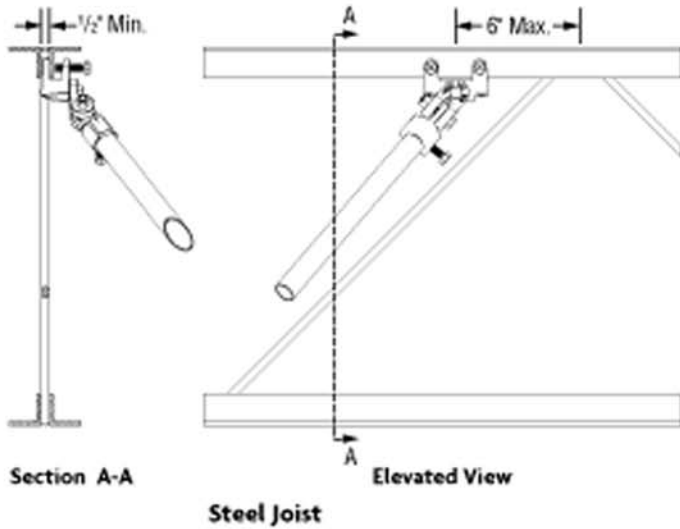



Fig. 778 - Bar Joist Beam Attachment



<b>FIG. 778 UL MAX LOADS: LOADS (LBS) • DIMENSIONS (IN)</b>		
Beam Flange Thickness	X Lateral	Z Longitudinal
$\frac{3}{16} - \frac{3}{4}$	2015	2015

<b>FIG. 778 FM MAX LOADS*: LOADS (LBS) • DIMENSIONS (IN) • ANGLES (DEGREES)</b>			
Beam Flange Thickness	Brace Angle**	X Lateral	Z Longitudinal
$\frac{1}{8} - \frac{3}{4}$ Bar Joist	30-44	440	620
	45-59	740	880
	60-74	920	940
	75-90	1010	1050
$\frac{1}{8} - \frac{3}{4}$ Wide Flange Beam	30-44	380	370
	45-59	540	520
	60-74	660	640
	75-90	700	720

\* The allowable FM approved capacity of brace subassemblies have been determined by resolving the load rating to the horizontal direction and dividing by a safety factor of 1.5 to allow the values to be used directly for Allowable Stress Design. For Load Resistance Factor Design (LRFD) capacities, the above values will need to be multiplied by 1.5.  
 \*\* Brace Pipe Angles are determined from vertical.

**Notes:**

1. For fire protection installations - sway braces are intended to be installed in accordance with NFPA-13 and Anvil's installations instructions and local codes.
2. The required type, number and size of fasteners used for the structural attachment fitting shall be in accordance with NFPA-13.
3. To assure proper performance, installer is responsible for:
  - a. Structural integrity of attachment member to safely handle load requirements.
  - b. Securely tightening the component on the brace pipe.
4. Anvil International® brand bracing components are designed to be compatible ONLY with other Anvil International® brand bracing components, resulting in a Listed seismic bracing assembly.

**Disclaimer:** Anvil International ("Anvil") does not provide any warranties and specifically disclaims any liability whatsoever with respect to Anvil bracing products and components that are used in combination with products, parts or systems not manufactured or sold by Anvil. In no event shall Anvil be liable for any incidental, direct, consequential, special or indirect damages or lost profits where non-Anvil bracing components have been, or are used.

**Structural Note:**

Steel Joist Manufacturers require that all seismic bracing connections be within 6" of the cord panel point. Installation of the Fig. 778 must be limited to the outer third sections of the joist span.

