



Sway Brace Seismic - Fig. 771 Sway Brace Swivel Fittings

Size Range: Brace Pipe: 1" or 1 1/4" Sch. 40 IPS

Service Line: 1" through 8"

Material: Ductile iron, shear head bolts and hex head mounting bolt

Finish: Plain or Galvanized

Service: Used to rigidly brace piping systems subjected to sway and seismic disturbances. Brace pipe fitting component of Anvil's 700 series sway brace assembly. Functions as a sway brace attachment that is directly attached to Fig. 772 Adjustable Beam Attachment, Fig. 778 Bar Joist Attachment and Fig. 779 Multi-Connector Adapter. Can be utilized as a brace fitting for either a lateral brace or a longitudinal brace, that can be mounted on horizontal or vertical structures.

Approvals: UL and ULC Listed (UL 203A:2009), and FM Approved (FM 1950:2010). Complies with seismic bracing requirements of NFPA-13.

Features:

- Requires no threading of bracing pipe
- Sway brace fitting designed for concentric loadings of seismic connections and fasteners.

Installation Instructions:

1. Mount Figure 771 Sway Brace Fitting to structure using suitable fasteners as defined by NFPA-13.
2. Place the Schedule 40 brace pipe into the brace pipe connector until it bottoms out.
3. Tighten shear bolt until the head shears off. The use of an impact wrench is not recommended.
4. Then position the brace pipe to the appropriate angle.
5. Ensure that the brace fitting hex bolt is tightened to a minimum torque value of 40 Ft-Lbs.

Ordering: Specify brace pipe diameter, figure number, name and finish.

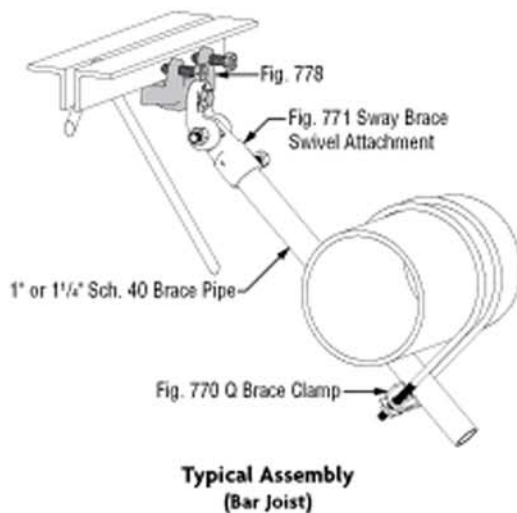
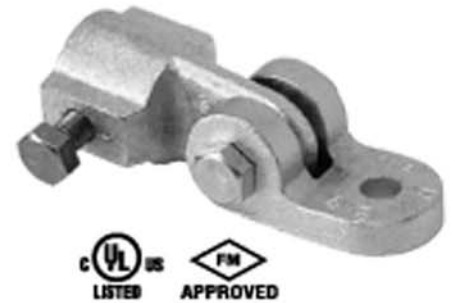



Fig. 771 - Sway Brace Swivel Fitting (cont.)

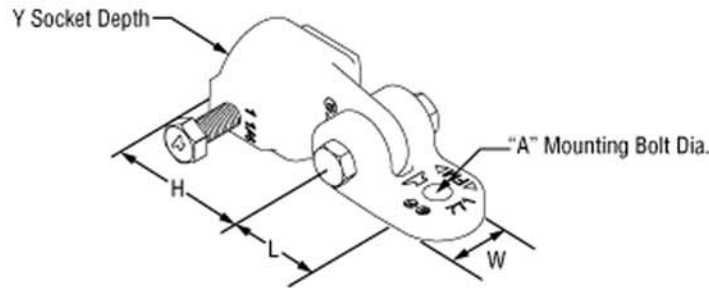

FIG. 771: WEIGHT (LBS) • DIMENSIONS (IN)

Brace Pipe Diameter Sch. 40	Bolt Diameter A	H	L	W	Y	Weight
1	1/2	2.85	1.65	1.69	1.38	1.95
1 1/4		2.98				2.28

**FIG. 771 FM MAX LOADS:
LOADS (LBS) • DIMENSIONS (IN) • ANGLES (DEGREES)**

Brace Pipe Diameter Sch. 40	Brace Angle*	FM Max Load
1 and 1 1/4	30° - 44°	1800
	45° - 59°	2500
	60° - 74°	3100
	75° - 90°	3400

**FIG. 771 UL MAX LOADS:
LOADS (LBS) • DIMENSIONS (IN)**

Brace Pipe Diameter Sch. 40	UL Max Load
1 and 1 1/4	2765

* Brace Pipe Angles are determined from vertical. The allowable FM approved capacity of brace subassemblies have been determined by resolving the load rating to the horizontal direction and dividing by a safety factor of 1.5 to allow the values to be used directly for Allowable Stress Design. For Load Resistance Factor Design (LRFD) capacities, the above values will need to be multiplied by 1.5.

Disclaimer: Anvil International (“Anvil”) does not provide any warranties and specifically disclaims any liability whatsoever with respect to Anvil bracing products and components that are used in combination with products, parts or systems not manufactured or sold by Anvil. In no event shall Anvil be liable for any incidental, direct, consequential, special or indirect damages or lost profits where non-Anvil bracing components have been, or are used.

Notes:

- For fire protection installations - sway braces are intended to be installed in accordance with NFPA-13 and Anvil's installations instructions and local codes.
- The required type, number and size of fasteners used for the structural attachment fitting shall be in accordance with NFPA-13.
- To assure proper performance, installer is responsible for:
 - Structural integrity of attachment member to safely handle load requirements.
 - Securely tightening the component on the brace pipe.
- Anvil International® brand bracing components are designed to be compatible ONLY with other Anvil International® brand bracing components, resulting in a Listed seismic bracing assembly.

