

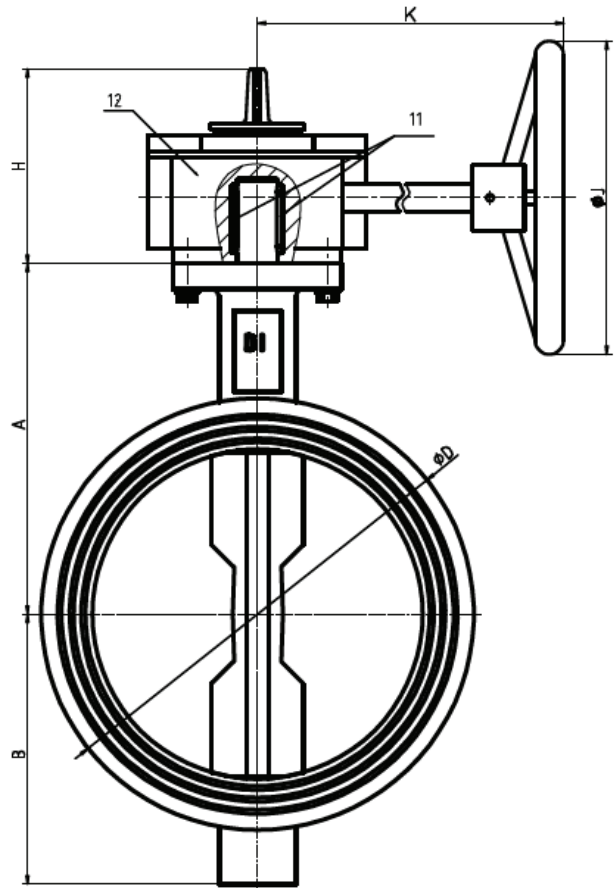

National Fire Equipment Ltd.

Model BFWO Wafer Supervised Butterfly Valve 12" 300 PSI Normally Open

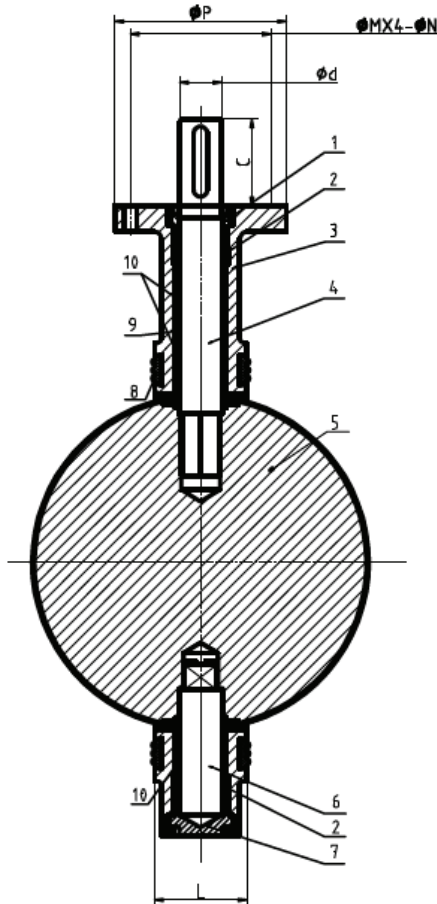

SIZE	A	B	C	D	H	K	J	P	M	N	d	L
12"	300	240	77	375	161	249	350	150	125	14	33	76.9

Note: It is UL/ULC/FM listed & approved

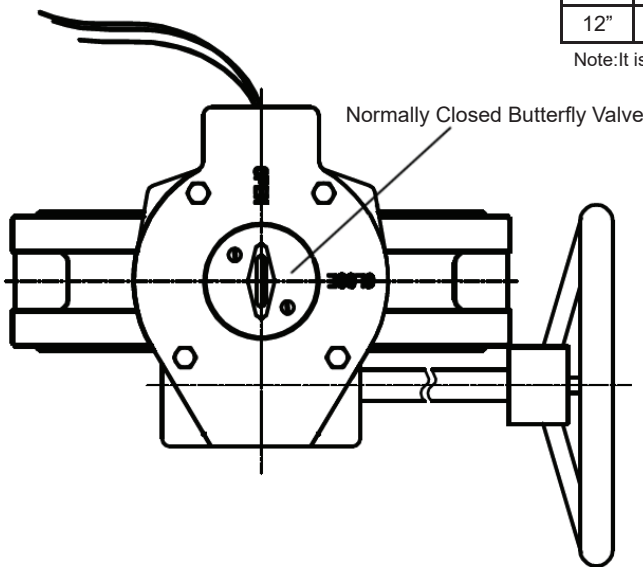

NO	Name	Material
1	Upper Shaft Sealing Nut	WCB
2	Shaft Seal	EPDM
3	Body	DI
4	Upper Shaft	SS416
5	Disc	DI+EPDM
6	Lower Shaft	SS416
7	Lower Shaft Sealing Nut	WCB
8	End Face Seal	EPDM
9	O-RING	EPDM
10	Stem Bushing	C95400+GRAPHITE
11	Key	WCB
12	Gear Box	



National Fire
Equipment Ltd.

TORONTO: (905) 761-6355
Toll Free: (800) 267-8508

OTTAWA: (613) 723-6071

VANCOUVER: (604) 420-1131
Toll Free: (800)-667-2138

BURNABY: (604)-299-4498

EDMONTON: (780) 455-3870
Toll Free: (888)-891-1008

CALGARY: (403) 236-5661

MONCTON: (506) 859-7277
Toll Free: (877) 816-3473

MISSISSAUGA: (905) 565-1385

www.nationalfire.com