

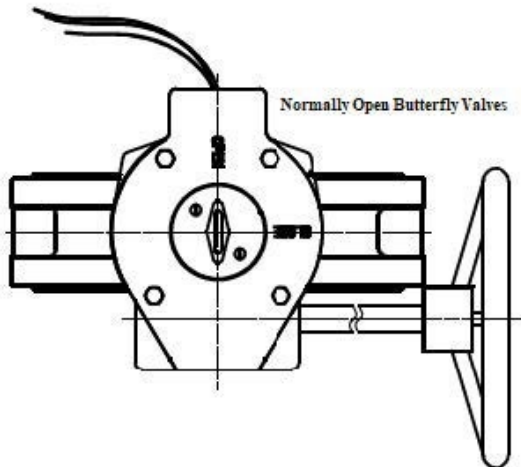

# National Fire Equipment Ltd.

**Model BFWO Wafer Supervised Butterfly Valve 10"**  
**300PSI Normally Open**

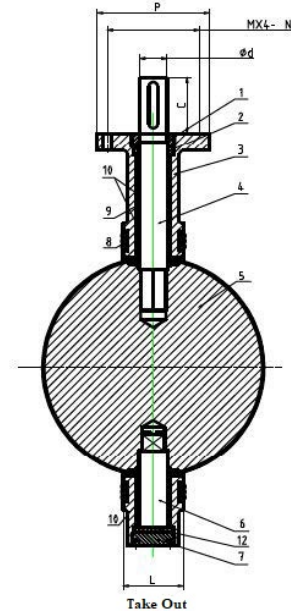
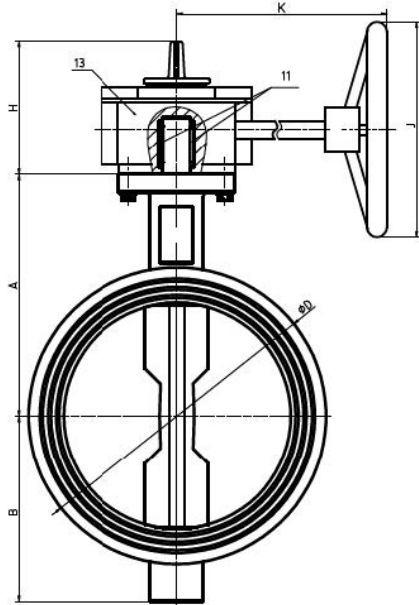

NO	NAME	MATERIAL
13	GEAR BOX	
12	LOWER SHAFT SEAL	EPDM
11	KEY	WCB
10	STEM BUSHING	C95400+GRAPHITE
9	O-RING	EPDM
8	END FACE SEAL	EPDM
7	LOWER SHAFT SEALING NUT	WCB
6	LOWER SHAFT	SS416
5	DISC	DI+EPDM
4	UPPER SHAFT	SS416
3	BODY	DI
2	UPPER SHAFT SEAL	EPDM
1	UPPER SHAFT SEALING NUT	WCB

SIZE	A	B	C	D	H	K	J	P	M	N	d	L	
10"	260	200	63	320	126	210	232	300	125	102	12	30.5	66.5

Max working pressure: 300 PSI (Max testing pressure: 600 PSI)

All valves are UL/ULC and F.M. approved up to 300 PSI

Valve is painted epoxy powder coating

Meets the requirements of NSF/ANSI Standard 61



**National Fire  
Equipment Ltd.**

TORONTO: (905) 761-6355

Toll Free: (800) 267-8508

OTTAWA: (613) 723-6071

VANCOUVER: (604) 420-1131

Toll Free: (800)-667-2138

BURNABY: (604)-299-4498

EDMONTON: (780) 455-3870

Toll Free: (888)-891-1008

CALGARY: (403) 236-5661

MONCTON: (506) 859-7277

Toll Free: (877) 816-3473

MISSISSAUGA: (905) 565-1385

[www.nationalfire.com](http://www.nationalfire.com)