

FRONT

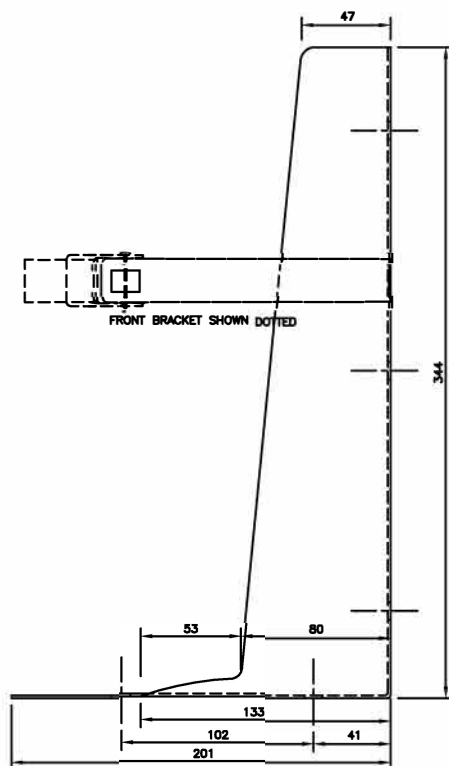

SIDE

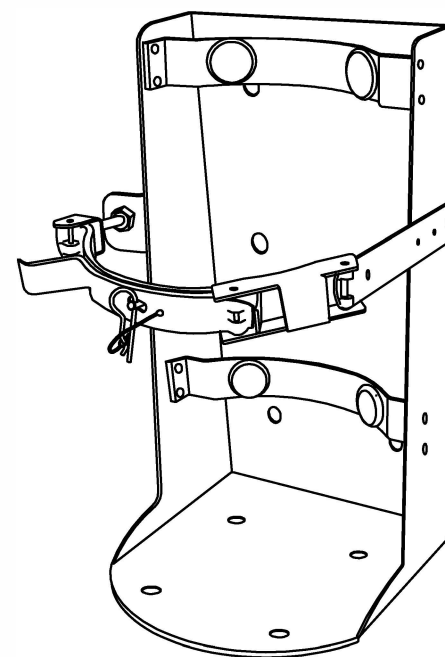

**Part # : HDVB-3**  
**Fits Diameter : 158.75mm - 180.97mm (6 1/4 - 7 1/8")**  
**For Strike First Models : WBDL-20**  
**SF-10C02**  
**SF-15 C O 2**

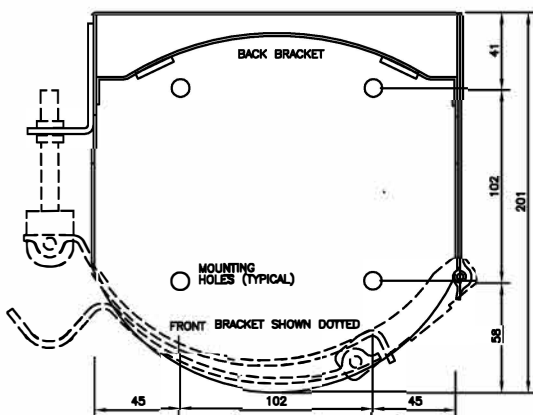

TOP

### HEAVY DUTY VEHICLE BRACKETS

- Strong Uni-Body Construction
- Scotchlite™ reflective label for added safety
- Stainless Steel pull pin
- Rounded corners for added safety
- Super durable polyester powder coat finish
- Individually boxed for easy handling



40 Edilcan Drive, Concord, Ontario, L4K 3S6  
 Tel: 905-761-6355 Toll Free: 1-800-267-8508  
[www.nationalfire.com](http://www.nationalfire.com)