

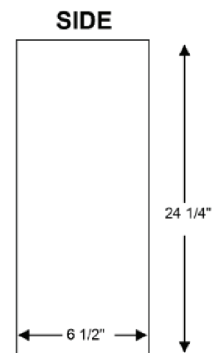

National Fire Equipment Ltd.

ECS-999 - 10lb. EXTINGUISHER CABINET

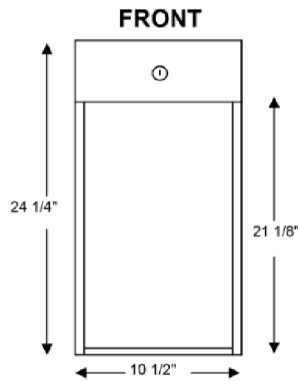
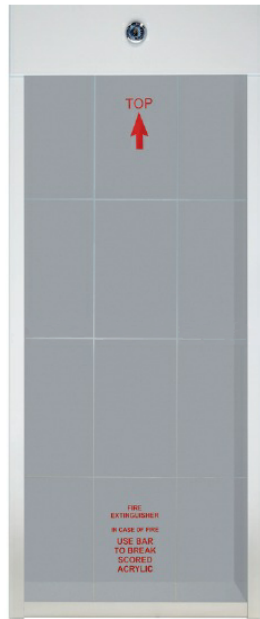

Optional Recessed Frame

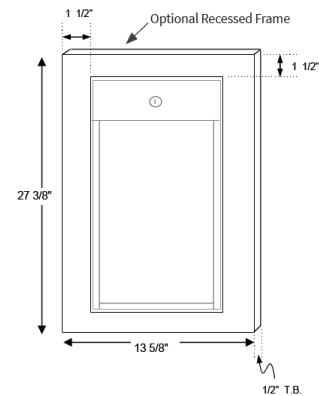

National Fire's Classic series are surface mounted cabinets that are both practical and economical. Theft and vandal resistant; these cabinets remain locked at all times, allowing emergency access through means of breaking the scored acrylic glass. Cabinets come complete with scored acrylic, breaker bar, key and decal (English & French). Perfect for parking garages, warehouses, industrial areas and construction sites.

Fire Extinguisher Capacity (Dry Chemical)	10 lb
Width	10 1/2 in
Height	24 1/4 in
Depth	6-1/2 in
Door & Tub	18 GA. Galvanneal Steel Construction
Finish	White Polyester Powder Coated Paint
Label	UV Resistant Decal
Includes	Keyed Alike Cylinder Lock with Key Breaker Bar & Chain Scored Acrylic (21-3/4" h X 10-3/8" w)

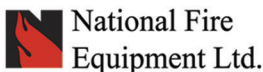

TORONTO: (905) 761-6355
Toll Free: (800) 267-8508
OTTAWA: (613) 723-6071

VANCOUVER: (604) 420-1131
Toll Free: (800)-667-2138
BURNABY: (604)-299-4498

EDMONTON: (780) 455-3870
Toll Free: (888)-891-1008
CALGARY: (403) 236-5661

MONCTON: (506) 859-7277
Toll Free: (877) 816-3473
MISSISSAUGA: (905) 565-1385

www.nationalfire.com