

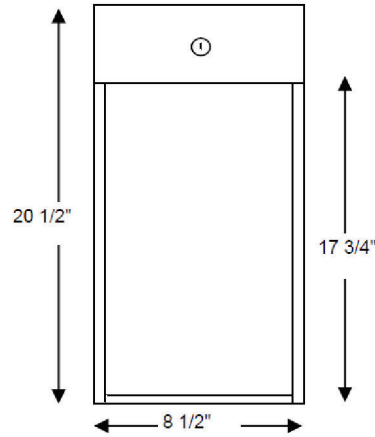

National Fire Equipment Ltd.

ECS-100 - 5lb. EXTINGUISHER CABINET

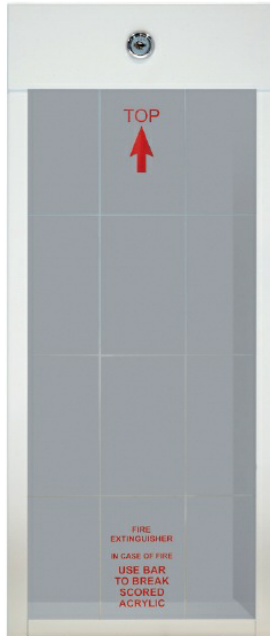

FRONT

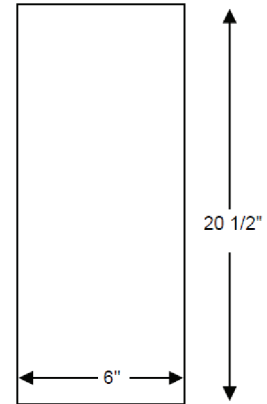

SIDE



Optional Recessed Frame

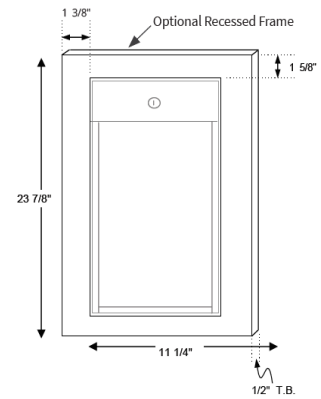

National Fire's Classic series are surface mounted cabinets that are both practical and economical. Theft and vandal resistant; these cabinets remain locked at all times, allowing emergency access through means of breaking the scored acrylic glass. Cabinets come complete with scored acrylic, breaker bar, key and decal (English & French). Perfect for parking garages, warehouses, industrial areas and construction sites.

Door & Tub	18GA. Galvanneal Steel Construction
Size	20 1/2"h X 8 1/2"w X 6"d
Finish	White Polyester Powder Coated Paint
Label	UV Resistant Decal
Includes	Keyed Alike Cylinder Lock with Key Scored Acrylic (17 7/8"h X 8"w)
Packaging	Breaker Bar & Chain Individually boxed