

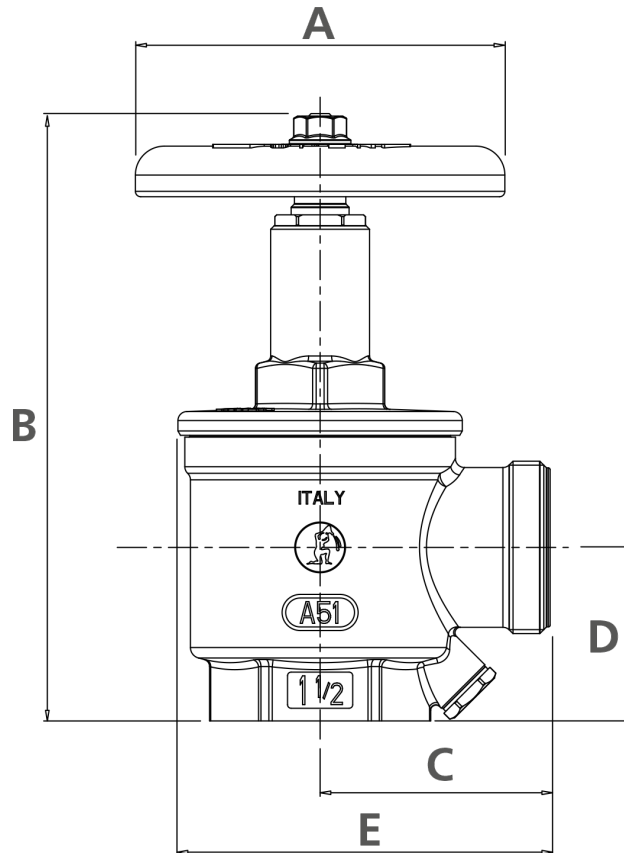

National Fire Equipment Ltd.

1.5" FIRE HOSE VALVE

*MODEL A51
1.5" FEMALE X MALE ANGLE HOSE VALVE WITH HYDROLATOR*



SIZE (a x b)	CERTIFICATIONS	A	B	C	D	E
1 1/2" x 1 1/2"	ULC 6158R	4 1/32"	7 19/32"	2 1/2"	1 7/8"	4 1/32"

Recommended for use with a stationary fire hose rack assembly. Female NPT inlet x male hose thread outlet forged brass valve. Red handwheel.

