

Model CWS Specific Application Concealed Pendent Vertical Sidewall Window Sprinkler 5.6 K-factor

General Description

The TYCO Model CWS Specific Application Concealed Pendent Vertical Sidewall Window Sprinkler is a fast response, solder-link type sprinkler which delivers water to window glazing in a horizontal pattern.

This sprinkler is the first concealed window sprinkler to be specifically Listed to provide complete wetting and coverage for heat strengthened, tempered, or ceramic glass windows using closed sprinklers. As part of the testing, the gas flow required to achieve the time/temperature relationship specified in ASTM E119 was established in a test furnace without sprinkler protection. A window assembly protected with the Model CWS Window Sprinkler was then installed in the test furnace, and the same gas flow conditions were maintained for a two-hour test period. No cracking or visible damage to the window was permitted during the test period.

The success of the Model CWS Window Sprinkler is based on its fast response thermal sensitivity and on its specially designed deflector which ensures the spray pattern wets the entire surface of the window.

Based on successful testing, the Model CWS Window Sprinkler can be used as interior protection for windows or glazing in a sprinklered building or non-sprinklered building in accordance

with Section 104 of the IBC ("Alternate Materials, Design and Methods of Construction and Equipment").

As with any specific application sprinkler, the installation instructions included in this data sheet must be precisely followed. If there are additional local or jurisdictional installation standards/codes for window sprinklers on glazed window systems, this document does not relieve the designer/installer from these requirements. Consult your local jurisdiction to verify if or when these additional guidelines must be followed.

NOTICE

TYCO Model CWS Specific Application Window Sprinkler described herein must be installed and maintained in compliance with this document, as well as with the applicable standards recognized by the approval agency, in addition to the standards of any authorities having jurisdiction. Failure to do so may impair the performance of these devices.

The owner is responsible for maintaining their fire protection system and devices in proper operating condition. Contact the installing contractor or product manufacturer with any questions.

Sprinkler Identification Number (SIN)

TY3498



Technical Data

Approvals
UL and C-UL Listed

Additional Recognition
ICC Evaluation Service (ESR-2397)

Pipe Thread Connection
1/2 in. NPT

Discharge Coefficient
K=5.6 GPM/psi^{1/2} (80,6 LPM/bar^{1/2})

Temperature Ratings
160°F (71°C) Sprinkler with
139°F (59°C) Cover Plate

212°F (100°C) Sprinkler with
165°F (74°C) Cover Plate

Finish
See Ordering Procedure section

Physical Characteristics

Body	Brass
Cap	Bronze
Saddle	Brass
Sealing Assembly	Beryllium Nickel w/TEFLON
Soldered Link Halves	Nickel
Lever	Bronze
Compression Screw	Brass
Deflector	Brass/Bronze
Guide Pin Housing	Bronze
Guide Pins	Stainless Steel
Support Cup	Steel
Cover Plate	Brass
Retainer	Copper
Cover Plate Ejection Spring	Stainless Steel

IMPORTANT

Refer to Technical Data Sheet TFP2300 for warnings pertaining to regulatory and health information.

Always refer to Technical Data Sheet TFP700 for the "INSTALLER WARNING" that provides cautions with respect to handling and installation of sprinkler systems and components. Improper handling and installation can permanently damage a sprinkler system or its components and cause the sprinkler to fail to operate in a fire situation or cause it to operate prematurely.

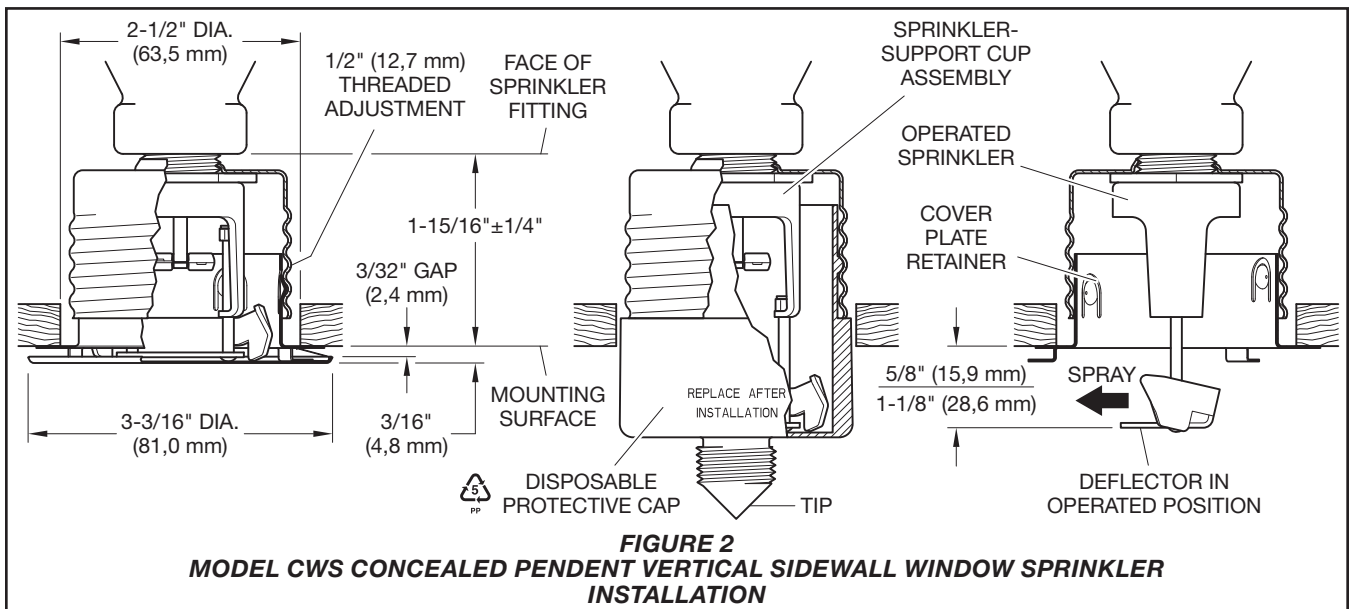
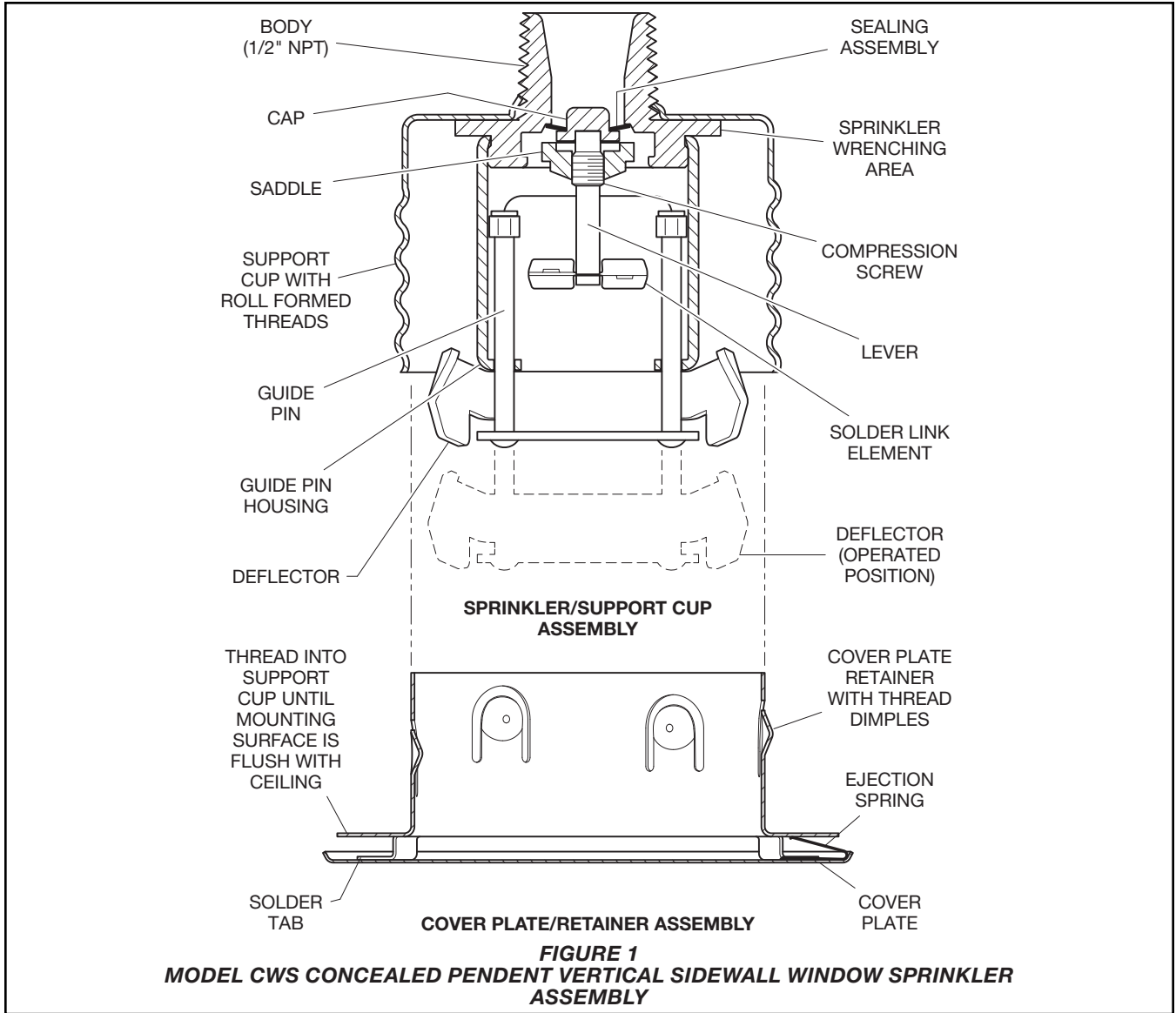

Operation

When exposed to heat from a fire, upon reaching the Cover Plate/Retainer Assembly temperature rating, the solder binding the Cover Plate to three tabs of the Retainer melts, allowing the Cover Plate to separate from the Retainer and exposing the Sprinkler/Support Cup Assembly. The Deflector, supported by the Guide Pins, deploys downward into the Operated Position.

As the temperature from the fire reaches the Sprinkler temperature rating, the solder binding the halves of the Solder Link Element melts, allowing the element to separate. With this linkage no longer holding the Sealing Assembly against the sprinkler orifice, water is allowed to flow through the waterway, spraying from the deflector in a pattern toward the window glazing.

Design Criteria

The TYCO Model CWS Specific Application Concealed Pendent Vertical Sidewall Window Sprinkler is UL and C-UL Listed.

This sprinkler is also Listed by Underwriters Laboratories of Canada (ULC) as providing a two-hour equivalency for a fire separation assembly when acceptable to the Authority Having Jurisdiction and installed in accordance with this code.

Area of Use

When acceptable to the authority having jurisdiction, and unless modified by a local jurisdictional standard or code mentioned previously, the Model CWS Window Sprinkler may be used in either a sprinklered or unsprinklered building to protect non-operable window openings that are part of a fire separation provided:

- in an interior fire separation, the window sprinklers are installed on both sides of the window in the fire separation (Figure 4A-1),
- in jurisdictions where exterior spatial separation (that is, separation from adjacent space) is defined as protecting an adjacent building from a fire in your building, window sprinklers are installed on the interior side of the building (Figure 4A-2).

System Protection Type

Interior: Wet Systems

Glass Type

The following types and thicknesses of glass are recognized for use with the Model CWS Window Sprinkler:

- Non-operable, heat-strengthened, tempered, single-glazed (single pane), not less than 1/4 in. (6 mm) thick;

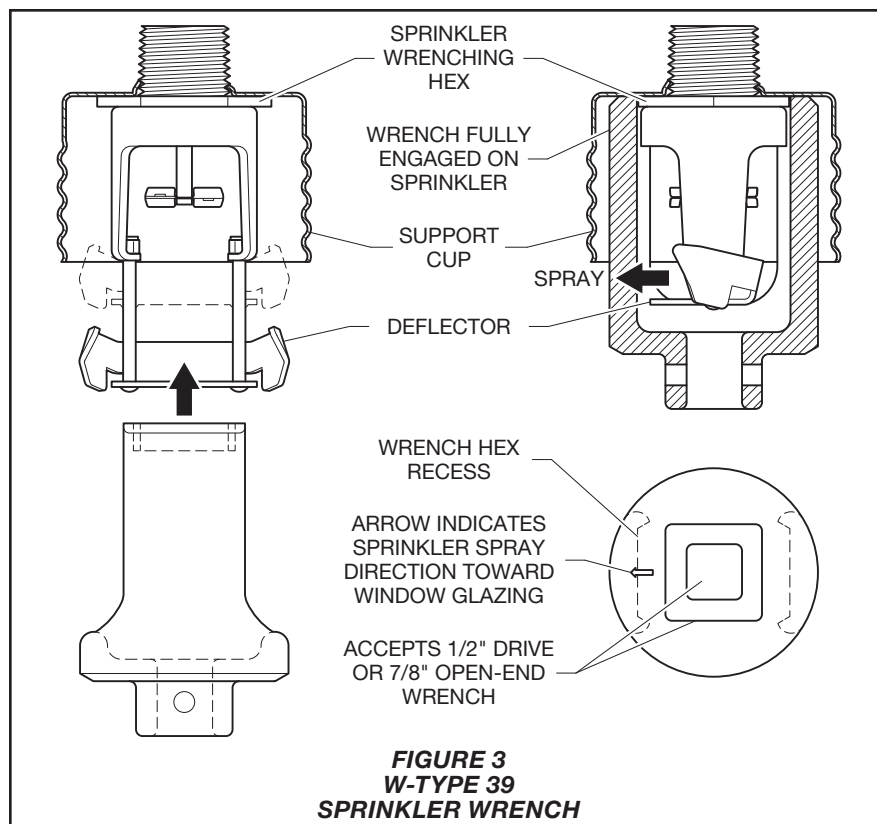

FIGURE 3
W-TYPE 39
SPRINKLER WRENCH

- Non-operable, heat-strengthened, tempered, double-glazed (double pane or insulated), not less than 1/4 in. (6 mm) thick;

- Non-operable, UL Classified and labeled FIRELITE PLUS CWS ceramic glass by TECHNICAL GLASS PRODUCTS (TGP), not less than 5/16 in. (8 mm) thick; or,

Note: Refer to FIRELITE PLUS CWS ceramic glass technical data sheet for other classification limitations at www.fireglass.com.

- Non-operable, stronger glass window assemblies, not less than 1/4 in. (6 mm) thick.

Type of Window Frame/Mullion

Non-combustible Frame with a standard EPDM rubber gasket seal

Vertical joints of glass panes must be connected by butt-joints using a silicone sealant between the individual panes or by Noncombustible Mullions.

(See Figures 4B-1 and 4B-2)

Maximum Length of Window Assembly

Unlimited

Maximum Height of Window Assembly

13 ft (3,96 m)

(See Figure 4B)

Maximum Distance Between Window Sprinklers

8 ft (2,44 m)

(See Figures 4B-1 and 4B-2)

Minimum Distance Between Window Sprinklers

6 ft (1,83 m) unless separated by a baffle or mullion of sufficient depth to act as a baffle.

A mullion will act as a baffle when the mullion extends to the back of the sprinkler deflector.

(See Figures 4B-1 and 4B-2)

Minimum Distance from Standard Sprinklers

6 ft (1,83 m) unless separated by a baffle

Sprinkler Location

- Mullioned Glazing Assemblies: Locate window sprinklers within each mullioned glazing segment. See Figure 4B-1.
- Butt-Jointed Glazing Assemblies: Locate window sprinklers on maximum 8 ft (2,44 m) centers. See Figure 4B-2.

Maximum Distance from Vertical Mullion

4 ft (1,22 m)

(See Figure 4B-1)

Minimum Distance from Vertical Mullions
 4 in. (101,6 mm)

(See Figure 4B-1)

Intermediate Horizontal Mullions
 Intermediate Horizontal Mullions were not tested with the Model CWS Window Sprinkler. Their use is outside the scope of the Specific Application Listing for the window sprinklers. See Figure 4B-3.

Deflector Location
 Sprinkler Deflectors must be located as described below in order to ensure that the entire surface of the glass window is covered. Sprinkler Deflectors are positioned with respect to the window frame, not the ceiling.

- **Model CWS Window Sprinkler:**
 Locate 6 in. to 12 in. (152,4 mm to 304,8 mm) from the face of the glass and 2 in. ± 2 in. (50,8 mm ± 50,8 mm) above the top of exposed glass. See Figure 4C.

Minimum Clearance from Face of Glass to Combustible Materials
 For glass types other than FIRELITE PLUS CWS ceramic glass by TGP, all combustible materials shall be kept 2 in. (50,8 mm) from the front face of the glass. This can be accomplished by a minimum 36 in. (914,4 mm) pony wall or other method acceptable to the authority having jurisdiction.

Recommended Hydraulic Requirements
 The authority having jurisdiction should be consulted to determine the hydraulic requirements for each installation.

Interior Protection Sprinklered Building
 Identify which compartmented area has the most hydraulically demanding window sprinklers. Calculate up to the most demanding 46.5 linear feet (14,2 linear meters) of Model CWS Window Sprinkler on one side of the glazing. The 46.5 linear feet (14,2 linear meters) is based upon 1.2 x the square root of the system area of operation, when the system area of operation is 1500 sq. ft in accordance with NFPA 13 Light/Ordinary Hazard density curves.

Where the area of Glazing is less than 46.5 linear feet (14.2 linear meters), all window sprinklers on one side shall be calculated.

When acceptable to the Authority Having Jurisdiction the Model CWS Specific Application Window Sprinkler may be used in either a sprinklered or unsprinklered building to protect nonoperable window openings that are in an interior fire separation, the window sprinklers are installed on both sides of the window in the fire separation.

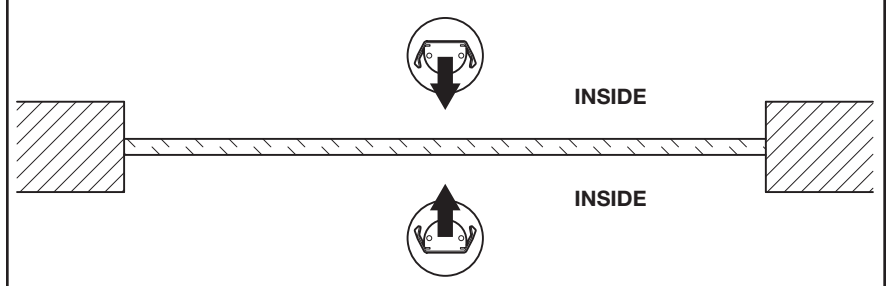

FIGURE 4A-1 - INTERIOR FIRE SEPARATION

When acceptable to the Authority Having Jurisdiction the Model CWS Specific Application Window Sprinkler may be used in either a sprinklered or unsprinklered building to protect nonoperable window openings that are part of a fire separation provided in jurisdictions where exterior spatial separation is defined as protecting an adjacent building from a fire in your building, window sprinklers are installed on the interior side of the glass.

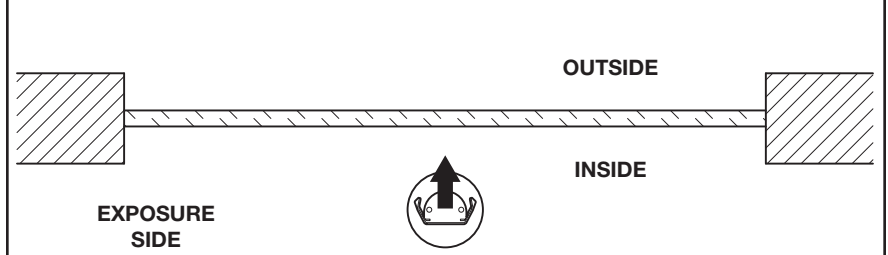

FIGURE 4A-2 - EXTERIOR FIRE SEPARATION - SPRINKLERS INSIDE

FIGURE 4A (A-1 AND A-2) TYPICAL NON-OPERABLE WINDOW OPENINGS

If an area reduction for quick response sprinklers is utilized, the linear length of the calculated window sprinklers may be reduced, but in no case shall be less than 36 linear feet (1.2 x √900).

If a single fire can be expected to operate Model CWS Window Sprinkler and sprinklers within the design area of a hydraulically calculated system, the water demand of the window sprinklers shall be added to the water demand of the hydraulic calculations and shall be balanced to the calculated area demand.

If the window sprinklers are located in an area other than the hydraulic design area, the demand of the window sprinklers is not required to be added to the demand of the remote hydraulic design area. However, it is necessary to prove hydraulically the simultaneous opera-

tion of the Model CWS Window Sprinkler and the ceiling sprinklers adjacent to the window sprinklers.

Interior Protection Non-Sprinklered Building
 Calculate all sprinklers on the most demanding side of the glazing assembly within the enclosure.

Duration of Water Supply
 Duration of water supply must comply with requirements of NFPA. If window sprinklers are used to provide the equivalency of a fire rating, the water supply must be capable of supplying water for the required rating period.

Minimum Flow per Sprinkler
 20 GPM (75,7 LPM) for sprinkler spacing of 6 ft to 8 ft (1,83 m to 2,44 m) or 15 GPM (56,8 LPM) for sprinkler spacing less than 6 ft (1,83 m).

Maximum Pressure per Sprinkler
 175 psi (12,07 bar)

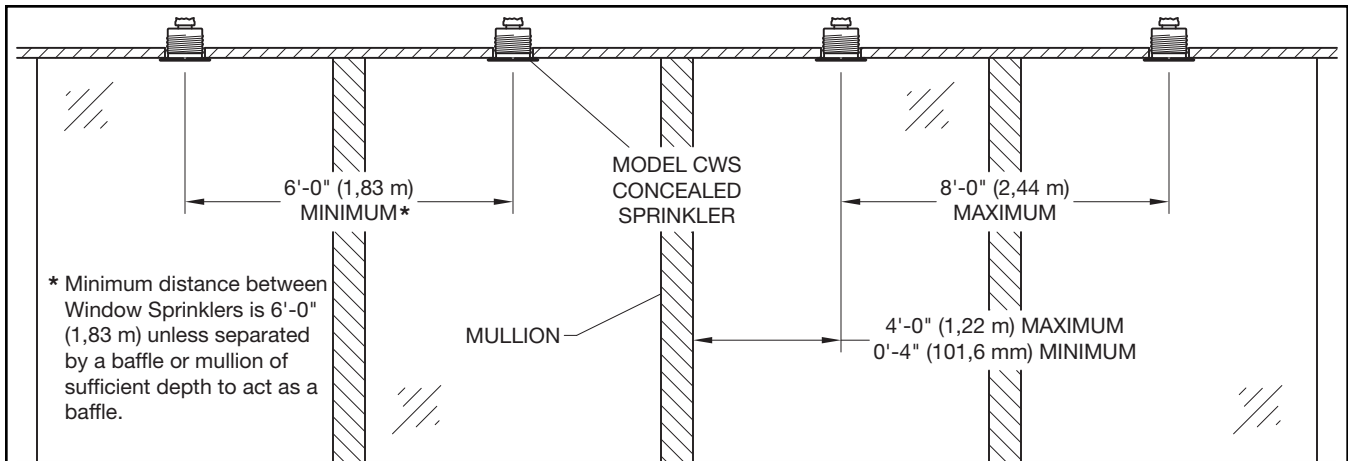

FIGURE 4B-1 - MULTIPLE WINDOWS SEPARATED BY MULLIONS

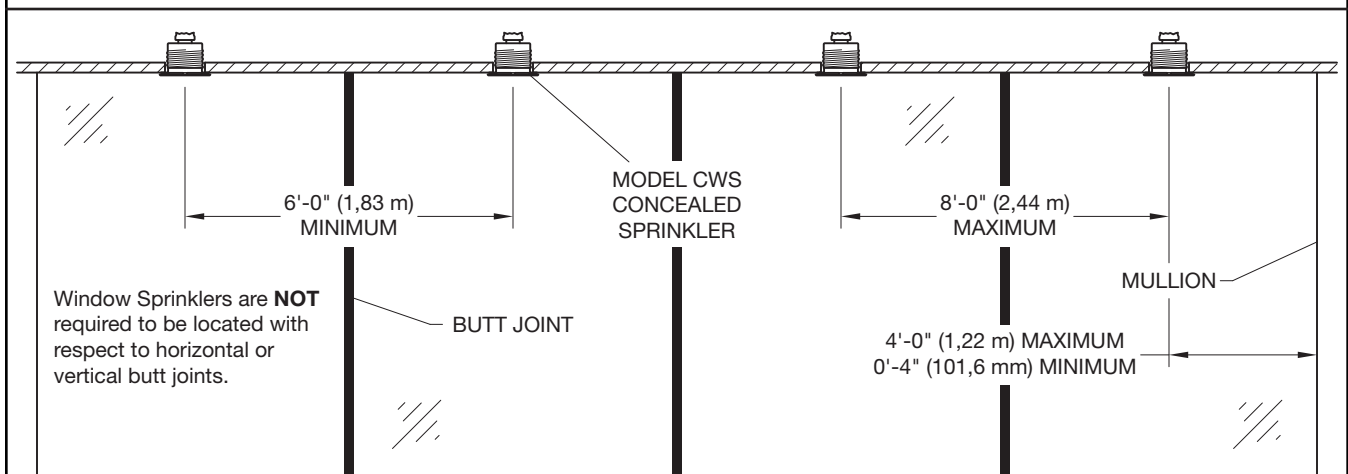

FIGURE 4B-2 - MULTIPLE WINDOWS SEPARATED BY BUTT JOINTS

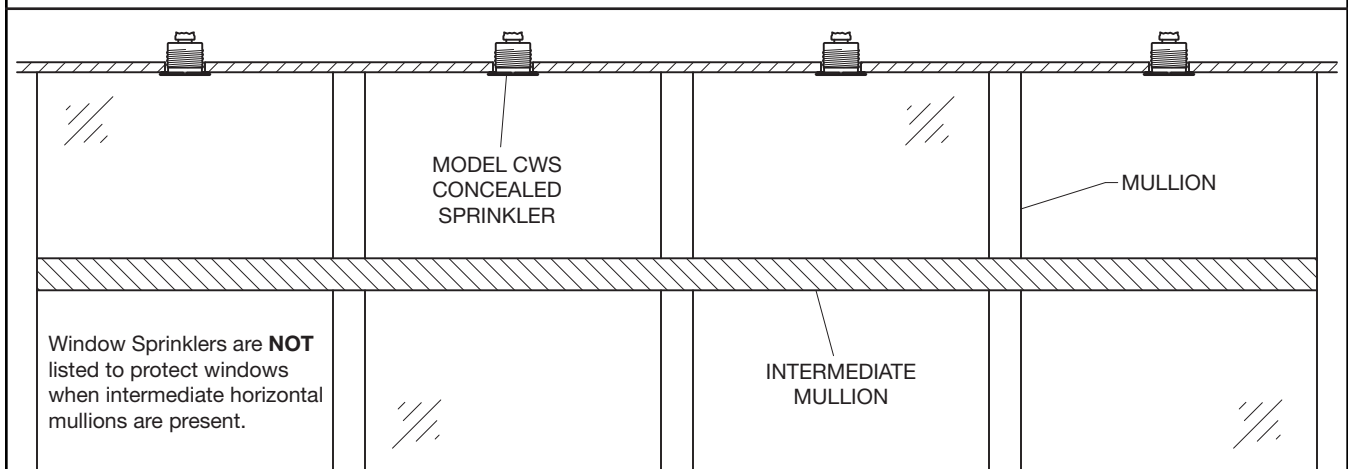
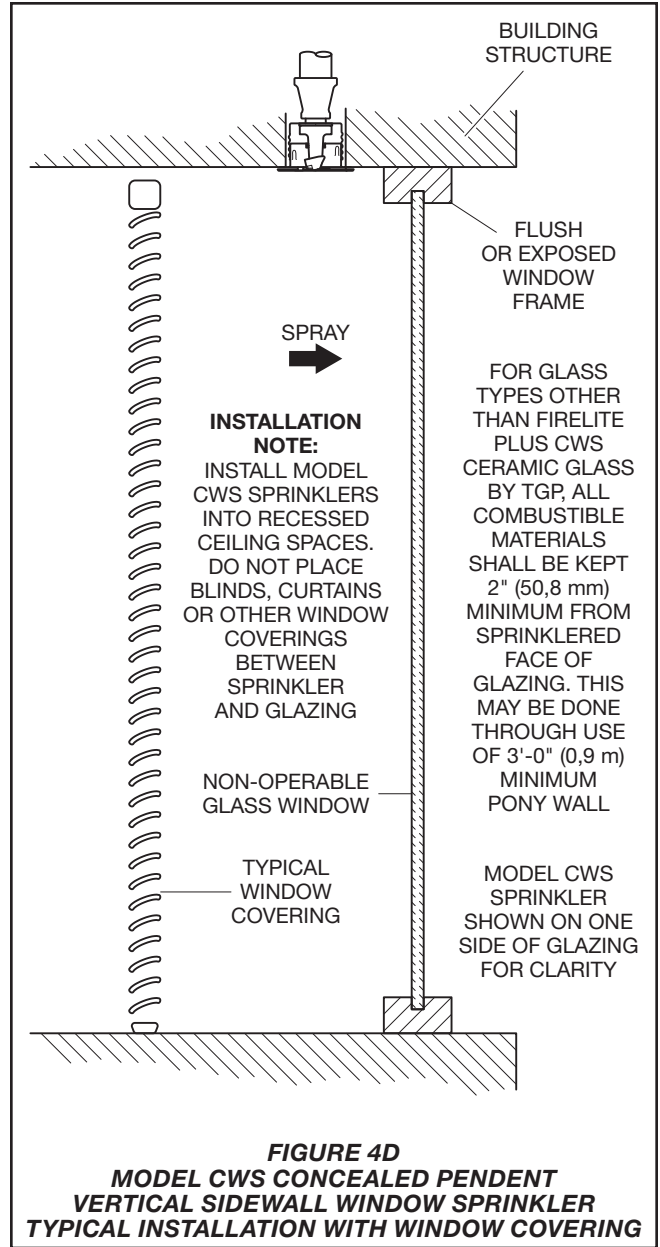
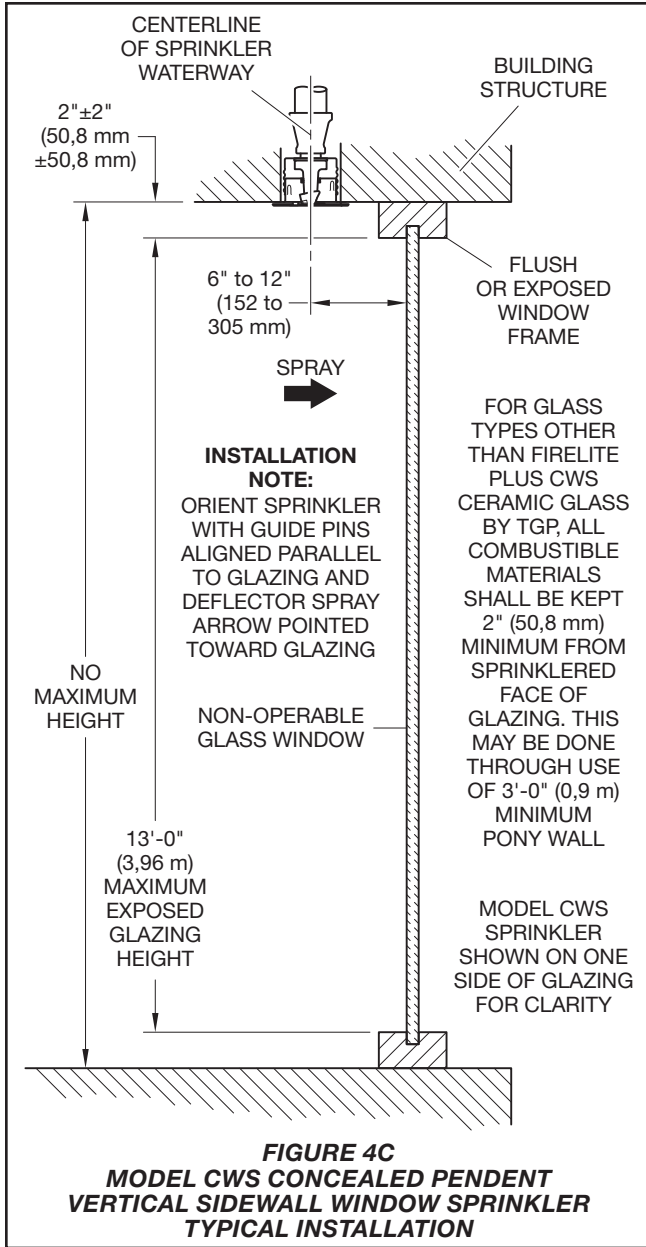

FIGURE 4B-3 - WINDOWS WITH HORIZONTAL MULLIONS

**FIGURE 4B (B-1 TO B-3)
WINDOW MULLIONS AND BUTT JOINTS**



Installation

The TYCO Model CWS Specific Application Window Sprinkler must be installed in accordance with this section.

General Instructions

A leak-tight 1/2 in. NPT sprinkler joint should be obtained by applying a minimum-to-maximum torque of 7 to 14 lb-ft (9,5 to 19,0 N·m). Higher levels of torque may distort the sprinkler inlet with consequent leakage or impairment of the sprinkler.

Do not attempt to compensate for insufficient adjustment in the Sprinkler by under- or over-tightening the Sprinkler/Support Cup Assembly. Re-adjust the position of the sprinkler fitting to suit.

Step 1. Install the Model CWS Window Sprinkler only in the pendent position with the center-line of the sprinkler parallel to the glass surface. Orient the sprinkler so that the direction of flow indicated on the sprinkler deflector is facing the window.

Step 2. Remove the Protective Cap.

Step 3. With pipe thread sealant applied to the pipe threads, and using the W-Type 39 Wrench, as shown in Figure 3, install and tighten the Sprinkler/Support Cup Assembly into the fitting. The W-Type 39 Wrench will accept a 1/2 in. ratchet drive.

Step 4. Replace the Protective Cap by pushing it upwards until it bottoms out against the Support Cup (see Figure 2). The Protective Cap helps prevent damage to the Deflector and Guide Pin Housing during ceiling installation and/or finish. You can also use the Protective Cap to locate the center of the clearance hole by gently pushing the ceiling material up against the center point of the Protective Cap.

NOTICE

As long as the Protective Cap remains in place, the system is considered "Out of Service".

Step 5. After the ceiling has been completed with the 2 1/2 in. (63,5 mm) diameter clearance hole and in preparation for installing the Cover Plate/Retainer Assembly, remove and discard the Protective Cap. Verify that the Deflector moves up and down freely. If the Sprinkler is damaged and the Deflector does not move up and down freely, replace the entire Sprinkler. Do not attempt to modify or repair a damaged sprinkler.

Step 6. Push on the Cover Plate Assembly until its flange comes in contact with the ceiling.

Do not continue to push on the Cover Plate Assembly such that it lifts a ceiling panel out of its normal position.

If the Cover Plate Assembly cannot be engaged with the Mounting Cup or the Cover Plate Assembly cannot be engaged sufficiently to contact the ceiling, the Sprinkler Fitting must be repositioned.

Care and Maintenance

The TYCO Model CWS Specific Application Window Sprinkler must be maintained and serviced in accordance with this section.

Before closing a fire protection system main control valve for maintenance work on the fire protection system that it controls, obtain permission to shut down the affected fire protection systems from the proper authorities and notify all personnel who may be affected by this action.

Absence of the Cover Plate Assembly may delay sprinkler operation in a fire situation. When properly installed, there is a nominal 3/32 in. (2,4 mm) air gap between the lip of the Cover Plate and the ceiling, as shown in Figure 2. This air gap is necessary for proper operation of the sprinkler. If the ceiling is to be repainted after the installation of the Sprinkler, care must be exercised to ensure that the new paint does not seal off any of the air gap.

Factory painted Cover Plates must not be repainted. They should be replaced, if necessary, by factory painted units. Non-factory applied paint may adversely delay or prevent sprinkler operation in the event of a fire.

Do not pull the Cover Plate relative to the Enclosure. Separation may result.

Sprinklers which are found to be leaking or exhibiting visible signs of corrosion must be replaced.

Automatic sprinklers must never be painted, plated, coated, or otherwise altered after leaving the factory. Modified sprinklers must be replaced. Sprinklers that have been exposed to corrosive products of combustion, but have not operated, should be replaced if they cannot be completely cleaned by wiping the sprinkler with a cloth or by brushing it with a soft bristle brush.

Care must be exercised to avoid damage to the sprinklers before, during, and after installation. Sprinklers damaged by dropping, striking, wrench twist/slippage, or the like, must be replaced. See the Installation section for additional information.

The owner is responsible for the inspection, testing, and maintenance of their fire protection system and devices in compliance with this document, as well as with the applicable standards recognized by the Approval agency, such as NFPA 25, in addition to the standards of any authorities having jurisdiction. Contact the installing contractor or product manufacturer regarding any questions.

Automatic sprinkler systems are recommended to be inspected, tested, and maintained by a qualified Inspection Service in accordance with local requirements and/or national codes.

Limited Warranty

For warranty terms and conditions, visit
www.tyco-fire.com.

Ordering Procedure

Contact your local distributor for availability. When placing an order, indicate the full product name and Part Number (P/N).

Model CWS Specific Applications Concealed Pendent Vertical Sidewall Window Sprinkler

Specify: Model CWS Specific Application Concealed Pendent Vertical Sidewall Window Sprinkler, SIN TY3498, (specify) temperature rating, and P/N (specify):

160°F (71°C)50-630-0-160
212°F (100°C)50-630-0-212

Note: Sprinkler and Cover Plates are separately sold. See Cover Plate Assemblies subsection for ordering information.

Cover Plate Assemblies

Specify: Model CWS Concealed Sprinkler Cover Plate Assembly, (specify) temperature rating, (specify) finish, P/N (specify):

139°F (59°C)^a
Ivory (RAL1015) 56-214-0-135
Bright Chrome 56-214-1-135
Beige (RAL1001) 56-214-2-135
Pure White (RAL9010)* 56-214-3-135
Signal White (RAL9003)** 56-214-4-135
Grey White (RAL9002) 56-214-5-135
Brown (RAL8028) 56-214-6-135
Black (RAL9005) 56-214-7-135
Brushed Brass 56-214-8-135
Brushed Chrome 56-214-9-135
Custom Paint 56-214-X-135

165°F (74°C)^b
Ivory (RAL1015) 56-214-0-165
Bright Chrome 56-214-1-165
Beige (RAL1001) 56-214-2-165
Pure White (RAL9010)* 56-214-3-165
Signal White (RAL9003)** 56-214-4-165
Grey White (RAL9002) 56-214-5-165
Brown (RAL8028) 56-214-6-165
Black (RAL9005) 56-214-7-165
Brushed Brass 56-214-8-165
Brushed Chrome 56-214-9-165
Custom Paint 56-214-X-165

a. For use with 160°F (71°C) sprinklers
b. For use with 212°F (100°C) sprinklers
* Eastern Hemisphere sales only
** Previously known as Bright White

Sprinkler Wrench

Specify: W-Type 39 Sprinkler Wrench,
P/N 56-000-1-950