

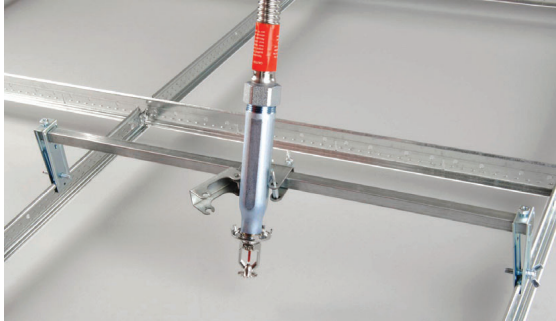

National Fire Equipment Ltd.

Flexible Sprinkler Hose Fittings

Series SFN Unbraided Flexible Hose Assemblies Series SFB Braided Flexible Hose Assemblies



SprinkFLEX Stainless Steel Sprinkler Fittings connect the branch line to the sprinkler using a flexible stainless steel hose and reducer. The flexible stainless steel hose and fittings are intended for direct connection to the sprinkler and are particularly suited for use in suspended and hard ceiling applications. Each drop assembly comes with one stainless steel flexible hose, one branch line connection nipple, one sprinkler reducing nipple and bracket system.

SYSTEM OPTIONS

- Pre-assembled, ready to install, unbraided and braided flexible stainless steel hose lengths: 28" (700mm), 40" (1000mm), 48" (1200mm), 59" (1500mm), 71" (1800mm)
- 1/2" and 3/4" outlet fittings for connecting sprinkler
- Pre-assembled, ready to install mounting bracket SF024BKT1 and SF048BKT1 available in 24" and 48" long
- Mounting bracket allows the sprinkler to be located anywhere within the ceiling with reference marks in the center for ease of installation without the need for measuring.
- Optional factory installed sprinkler head.

TECHNICAL DATA

- Maximum Working Pressure: 200 psi (1375 kPa)
- Maximum Ambient Temperature: 300° F (149°C)
- Connection to Branch Line: 1-inch NPT
- Minimum Bend Radius of Flexible Stainless Steel Hose:
3" (76.2 mm) per UL Listing
8" (203.2 mm) per FM Approval
The flexible stainless steel hose should not be bent within 2 1/2" (64 mm) of the connection nut at both ends.
- Listings and Approvals:
Unbraided models are UL Listed
Braided models are FM Approved and UL Listed



National Fire
Equipment Ltd.

TORONTO: (905) 761-6355
Toll Free: (800) 267-8508

OTTAWA: (613) 723-6071

VANCOUVER: (604) 420-1131
Toll Free: (800)-667-2138

BURNABY: (604)-299-4498

EDMONTON: (780) 455-3870
Toll Free: (888)-891-1008

CALGARY: (403) 236-5661

MONCTON: (506) 859-7277
Toll Free: (877) 816-3473

MISSISSAUGA: (905) 565-1385

www.nationalfire.com



National Fire Equipment Ltd.

Flexible Sprinkler Hose Fittings

FLEXIBLE HOSE - NON BRAIDED: SFN SERIES BELOW



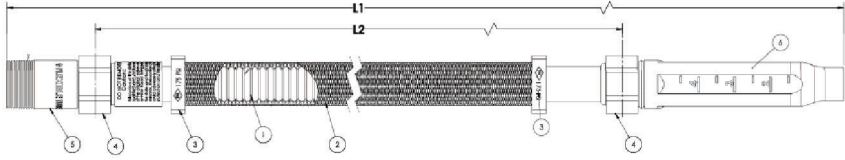

NO.	Description	NO.	Description
1	Flexible Hose 7/8" ID	3	Nipple
2	Slip Nut	4	1/2" to 3/4" Reducer

FLEXIBLE HOSE - BRAIDED: SFB SERIES BELOW



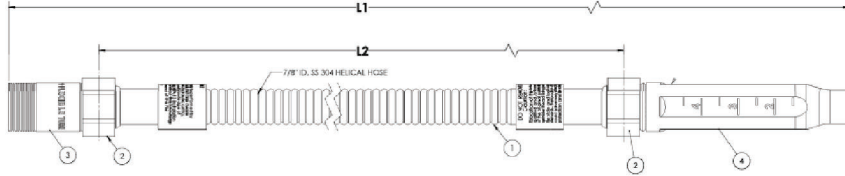

NO.	Description	NO.	Description
1	Flexible Hose 7/8" ID	4	Slip Nut
2	Braid	5	Nipple
3	Ring Collar	6	Reducer 1/2" to 3/4"

BRACKET ASSEMBLY: SFO24BKT1 & SFO48BKT1 BELOW



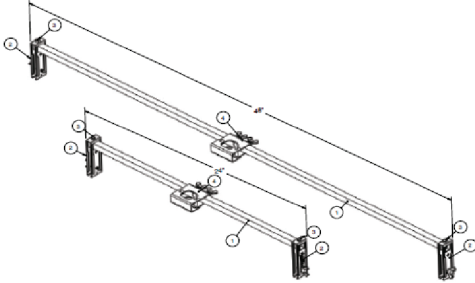

NO.	Description	QTY*	NO.	Description	QTY*
1	24" or 48" Support Bracket	1	3	Hex Screw	2
2	Bracket Legs Assembly	2	4	Hub A Assembly	1

MATERIAL SPECIFICATION

Corrugated Flex Hose: SS304	Support Bar: G90 Galvanized Steel
Seal: EPDM	Clamp and Center Bracket Assembly: Zinc-Plated Carbon Steel
Slip Nut and Nipple: Zinc-Plated Carbon Steel	Hex Screw and Wing Bolt: Zinc-Plated Carbon Steel
Braid and Braid Ring: : SS304	Optional Temper-Resistant Screw: Zinc-Plated Carbon Steel

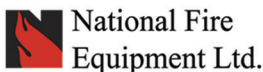

TORONTO: (905) 761-6355
Toll Free: (800) 267-8508
OTTAWA: (613) 723-6071

VANCOUVER: (604) 420-1131
Toll Free: (800)-667-2138
BURNABY: (604)-299-4498

EDMONTON: (780) 455-3870
Toll Free: (888)-891-1008
CALGARY: (403) 236-5661

MONCTON: (506) 859-7277
Toll Free: (877) 816-3473
MISSISSAUGA: (905) 565-1385

www.nationalfire.com



National Fire Equipment Ltd.

Flexible Sprinkler Hose Fittings

HOSE MODEL:

SFB28, SFB40, SFB48, SFB59, SFB71 Braided
SFN28, SFN40, SFN48, SFN59, SFN71
Unbraided



BRACKET MODEL:

SFO24BKT1
SFO48BKT1



Our SprinkFLEX flexible sprinkler hose fitting has limited flexibility and intended to use for direct connection to fire sprinkler in wet systems in accordance with NFPA 13, 13D and 13R. Our SprinkFLEX flexible sprinkler hose fitting can be installed for use in ceilings with grids which meets ASTM C635 and ASTM C636 referenced by IBC, and is approved for use in standard intermediate and heavy duty structural classification.

1 Determine the place where the sprinkler head will be located. The standard bracket SFO24BKT1 is 24 inches (600mm) long and shall be mounted on the 24 inch (600mm) ceiling grid. The long bracket SFO48BKT1 is 48 inches long (1200mm) long and shall be mounted on the 48 inch (1200mm) ceiling grid. The sprinkler should be located as close as possible to the center of the distance between ceiling grids (if necessary).

2 Slide reducer bracket onto the cross support bar. Loosely attach the reducer bracket and two clamps on the support bar and place clamps onto ceiling grid so that they support bar crosses the location where the sprinkler will be located (if necessary). See Fig 1.



3 Separate nipple (if necessary) from the flexible hose and attach the nipple onto the branch line. Make sure that the arrow is in the appropriate direction of flow to the sprinkler and to use pipe thread sealant and/or Teflon tape at the connection to the branch line. See Fig. 2. Attach one end of the flexible hose on to the nipple and tighten the slip nut to hand tight plus 1/2 turn (equivalent to 15 ft-LBS.) Do not twist the flexible hose. See Fig. 3.

4 Bend the flexible hose into a curve that locates the sprinkler reducer at the other end of the flexible hose in the area where the sprinkler will be located. The tube arc should not be twisted and arc should be as large and smooth as possible. The minimum bending radius is 3 inch (76.2 mm) per UL Listing and 8 inch (203mm) per FM Approval. FLEXIBLE HOSES ARE NOT TO BE INSTALLED STRAIGHT (NO BENDS). THE FLEXIBLE STAINLESS STEEL HOSE SHOULD NOT BE BENT WITHIN 2 1/2 INCHES (64 MM) OF THE CONNECTION NUT AT BOTH ENDS.

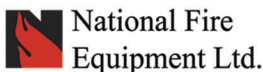

TORONTO: (905) 761-6355
Toll Free: (800) 267-8508
OTTAWA: (613) 723-6071

VANCOUVER: (604) 420-1131
Toll Free: (800)-667-2138
BURNABY: (604)-299-4498

EDMONTON: (780) 455-3870
Toll Free: (888)-891-1008
CALGARY: (403) 236-5661

MONCTON: (506) 859-7277
Toll Free: (877) 816-3473
MISSISSAUGA: (905) 565-1385

www.nationalfire.com



National Fire Equipment Ltd.

Flexible Sprinkler Hose Fittings

5 Insert the sprinkler reducer into bracket, close hub and lock shaft on reducer bracket. Locate the reducer bracket and sprinkler reducer where the sprinkler will be, and loosely tighten the butterfly bolts on the bracket. See Figure 4A.



6 Attach the sprinkler to the sprinkler reducer. Put a wrench on the sprinkler reducer to counteract the tightening torque and prevent the flexible hose from twisting. Reference the sprinkler manufacturer's sprinkler data sheet for appropriate sprinkler tightening torque, sprinkler wrench and other guidance.

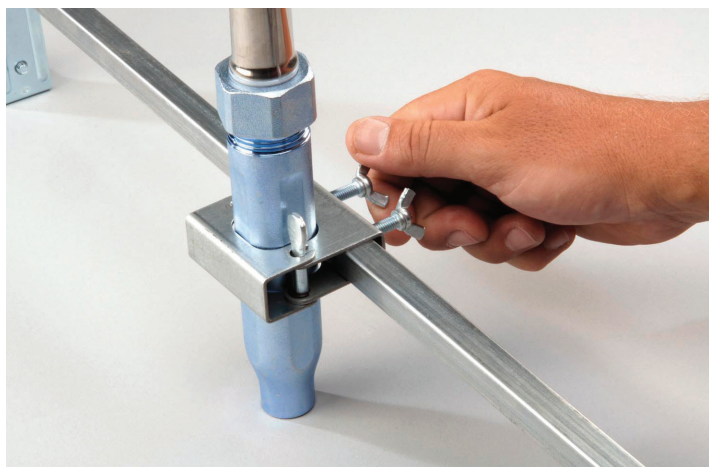

7 Verify that the sprinkler reducer is seated in the reducer bracket, precisely locate the sprinkler in all three axis in accordance with the sprinkler manufacturer's data sheet. Tighten all butterfly bolts on clamps and bracket. The torque requirements for butterfly bolts are minimum 40 in-lb and maximum 50 in-lb. See Fig 4B.

8 After tightening all the bolts, verify that the sprinkler is properly located in accordance with the manufacturer's instruction. If not, loosen the butterfly bolts and readjust as required. See Fig 5.



WARNING

- Read and understand all instructions before attempting to install any SprinkFLEX® products.
- Wear safety glasses, hardhat, and foot protection during installation.
- These installation instructions are intended for an experienced, trained installer.
- The user must understand the purpose of these products, common industry standards for safety, and the potential consequences of improper product installation.
- Failure to follow these installation instructions could cause improper sprinkler operation, resulting in serious personal injury and/or property damage. Installation for ASTM C635 metal ceiling suspension systems installed in accordance with ASTM C636 standards.



**National Fire
Equipment Ltd.**

TORONTO: (905) 761-6355
Toll Free: (800) 267-8508

OTTAWA: (613) 723-6071

VANCOUVER: (604) 420-1131
Toll Free: (800)-667-2138

BURNABY: (604)-299-4498

EDMONTON: (780) 455-3870
Toll Free: (888)-891-1008

CALGARY: (403) 236-5661

MONCTON: (506) 859-7277
Toll Free: (877) 816-3473

MISSISSAUGA: (905) 565-1385

www.nationalfire.com



National Fire Equipment Ltd.

Flexible Sprinkler Hose Fittings

FRICTION LOSS DATA & SPECIFICATIONS												
MODEL NUMBER	INLET SIZE (INCHES) CM	OUTLET ORIFICE SIZE (INCHES) CM	HOSE ASSEMBLY LENGTH [L] INCHES (mm)	MINIMUM BEND RADIUS		MAX NUMBER OF 90° BENDS		EQUIVALENT LENGTH OF 1in. DIAMETER SCHEDULE 40 PIPE FT (m)			MAX RATED WORKING PRESSURE	
				FM in. (mm)	UL in. (mm)	UL	FM	(UL)	(FM) 5.6 k-factor	(FM) 8.0 k-factor	UL PSI (KPA)	FM PSI (KPA)
1" INTERNAL DIAMETER (I.D.) HOSE SERIES												
SFB-28	1 (2.54)	1/2 (1.27)	27 (700)	8 (203)	3 (76.2)	2	1	24	18.6 (5.7)	-	200 (1379)	175 (1205)
SFB-40			39 (1000)			3	1	44	24.6 (7.5)	-		
SFB-48			47 (1200)			3	3	63	28.5 (8.6)	-		
SFB-59			59 (1500)			3	3	76	34.4 (10.4)	-		
SFB-71			71 (1800)			3	4	78	40.4 (12.3)	-		
SFB-28	1 (2.54)	3/4 (1.90)	27 (700)	8 (203)	3 (76.2)	2	1	29	-	18.8 (5.7)	200 (1379)	175 (1205)
SFB-40			39 (1000)			3	1	54	-	24.8 (7.6)		
SFB-48			47 (1200)			3	3	55	-	28.7 (8.7)		
SFB-59			59 (1500)			3	3	70	-	36.6 (10.5)		
SFB-71			71 (1800)			3	4	92	-	40.6 (12.4)		
SFB-28 -E	1 (2.54)	1/2 (1.27)	27 (700)	8 (203)	-	-	1	-	20.6 (6.3)	-	-	175 (1205)
SFB-40 -E			39 (1000)			-	1	-	26.6 (8.1)	-		
SFB-48 -E			47 (1200)			-	3	-	30.5 (9.3)	-		
SFB-59 -E			59 (1500)			-	3	-	36.4 (11.1)	-		
SFB-71 -E			71 (1800)			-	4	-	42.4 (12.9)	-		
SFB-28 -E	1 (2.54)	1/2 (1.27)	27 (700)	8 (203)	-	-	1	-	-	20.8 (6.3)	-	175 (1205)
SFB-40 -E			39 (1000)			-	1	-	-	26.8 (8.2)		
SFB-48 -E			47 (1200)			-	3	-	-	30.7 (9.4)		
SFB-59 -E			59 (1500)			-	3	-	-	36.6 (11.2)		
SFB-71 -E			71 (1800)			-	4	-	-	42.6 (13.0)		
SFN-28	1 (2.54)	1/2 (1.27)	27 (700)	-	3 (76.2)	2	-	22	-	-	200 (1379)	-
SFN-40			39 (1000)			3	-	39	-	-		
SFN-48			47 (1200)			3	-	56	-	-		
SFN-59			59 (1500)			3	-	59	-	-		
SFN-71			71 (1800)			3	-	67	-	-		
SFN-28	1 (2.54)	1/2 (1.27)	27 (700)	-	3 (76.2)	2	-	28	-	-	200 (1379)	-
SFN-40			39 (1000)			3	-	54	-	-		
SFN-48			47 (1200)			3	-	63	-	-		
SFN-59			59 (1500)			3	-	74	-	-		
SFN-71			71 (1800)			3	-	74	-	-		

NOTES:

- * MODEL NUMBERS: THE "SFN" DESIGNATES SPRINKFLEX UNBRAIDED HOSE SERIES. THE "SFB" DESIGNATES SPRINKFLEX BRAIDED HOSE SERIES, THE "E" DESIGNATES ELBOW.
- * MAX AMBIENT TEMPERATURE RATING ON ALL MODEL NUMBERS ARE 300°F (148°C).
- * EQUIVALENT LENGTHS ARE SHOWN WITH MAXIMUM NUMBER OF 90 DEGREE BENDS AT THE MINIMUM BEND-RADIUS PER AGENCY. 2- 45 DEGREE OR 3-30 DEGREE BENDS EQUAL 1-90 DEGREE BEND.
- DIFFERENT VALUES WERE OBTAINED BY FM AND UL DUE TO THE DIFFERENCE IN MINIMUM BEND RADIUS, TESTING PROTOCOL AND CALCULATION METHODS.
- PLEASE SEE INDIVIDUAL STANDARDS FOR MORE INFORMATION RELATIVE TO FRICTION LOSS (EQUIVALENT LENGTH OF PIPE).
- * FM EQUIVALENT LENGTH CALCULATION INCLUDES SPRINKLER HEAD FRICTION LOSS.
- * SEE LISTING(S) APPROVAL AGENCY FOR THE LATEST APPROVAL DETAILS.

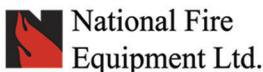

TORONTO: (905) 761-6355
Toll Free: (800) 267-8508
OTTAWA: (613) 723-6071

VANCOUVER: (604) 420-1131
Toll Free: (800)-667-2138
BURNABY: (604)-299-4498

EDMONTON: (780) 455-3870
Toll Free: (888)-891-1008
CALGARY: (403) 236-5661

MONCTON: (506) 859-7277
Toll Free: (877) 816-3473
MISSISSAUGA: (905) 565-1385

www.nationalfire.com



National Fire Equipment Ltd.

Flexible Sprinkler Hose Fittings

IMPORTANT INSTALLATION INFORMATION

- SprinkFLEX products must be installed according to current, applicable National Fire Protection Association (NFPA 13, 13D, 13R, etc.) standards or equivalent standards for wet, dry, or pre-action systems. Deviations from these standards or alterations to SprinkFLEX products or sprinklers will void any warrant. In addition, installations must meet provision of the local authority having jurisdiction and local codes, as applicable.
- For suspended ceiling applications, the ends of the SprinkFLEX Bracket must be installed to the rails of an ASTM C635 ceiling installed in accordance with ASTM C636 standards.
- SprinkFLEX Stainless Steel Sprinkler Fittings and/or the SprinkFLEX Bracket must not be intermixed with other manufacturer's products.
- Refer to the specific product submittal for applications and listing information. These submittals are located on the website at www.sprinkflex.com.
- Size the piping system to provide the minimum required flow rate for the sprinkler system.
- Flush the system to remove foreign material. Continue to flush the system until water runs clear.
- DO NOT install sprinkler system piping through heating ducts.
- DO NOT connect sprinkler system piping to domestic hot water systems.
- DO NOT install sprinklers where they will be exposed to temperatures that exceed the maximum ambient temperature rating for the sprinkler.
- The flexible stainless steel hose should not be bent or fluctuated up-and-down or side-to-side when it is pressurized for test.
- The flexible stainless steel hose should not be bent within 2 1/2 inches/64 mm of the connection nut at both ends.
- Flexible stainless steel hose and fittings have limited flexibility and are intended only to be installed with bends at their respective minimum bend radii.
- Protect wet piping systems for freezing temperatures.
- If construction is altered, refer to applicable standards to determine if additional sprinklers are required.
- The owner is responsible for maintaining the fire protection system in proper operating condition.
- For minimum maintenance and inspection requirements, refer to NFPA 25 and the NFPA pamphlet that describes the care and maintenance of sprinkler systems. In addition, the authority having jurisdiction may have additional maintenance, testing, and inspection requirements that must be followed.
- UL Maximum K-Factor of Sprinkler to be connected to Sprinkler Reducing Nipple:
1/2" outlets: 8.0
3/4" outlets: 11.2



National Fire
Equipment Ltd.

TORONTO: (905) 761-6355
Toll Free: (800) 267-8508

OTTAWA: (613) 723-6071

VANCOUVER: (604) 420-1131
Toll Free: (800)-667-2138

BURNABY: (604)-299-4498

EDMONTON: (780) 455-3870
Toll Free: (888)-891-1008

CALGARY: (403) 236-5661

MONCTON: (506) 859-7277
Toll Free: (877) 816-3473

MISSISSAUGA: (905) 565-1385

www.nationalfire.com