



National Fire Equipment Ltd.



Series 994RPDA Reduced Pressure Detector Assemblies Sizes 2 1/2" – 6" (65 – 150mm)

Series 994RPDA Reduced Pressure Detector Assemblies are designed for use in accordance with water authority-containment programs. This series is normally used in health hazard applications to protect against backsiphonage and backpressure. This series can be used to prevent the reverse flow of fire protection substances, i.e., glycerin wetting agents, foam agents, stagnant water, auxiliary supplies and water of non-potable quality from being pumped or siphoned into the potable water supply.

Features

- Stainless steel construction provides long term corrosion resistance and maximum strength
- Stainless steel body is half the weight of competitive designs reducing installation and shipping costs
- Short end to end dimensions makes retrofit easy
- Bottom mounted relief valve reduces clearance requirements when installed against an outside wall
- Torsion spring check valves provides maximum flow at low pressure drop
- Thermoplastic & stainless steel check valves for trouble-free operation
- No special tools required for servicing
- Compact construction allows for smaller enclosures
- Stainless steel relief valve features a balanced rolling diaphragm to eliminate sliding seals and lower maintenance costs
- Detects underground leaks and unauthorized water use.
- GPM or CFM meter available

Specifications

A Reduced Pressure Detector Assembly shall be installed at each cross-connection to prevent backsiphonage and backpressure of hazardous materials into the potable water supply. The assembly shall consist of a pressure differential relief valve located in a zone between two positive seating check valves. The main valve body shall be manufactured from 300 Series stainless steel for corrosion resistance. The check valves shall be of thermoplastic construction with stainless steel hinge pins, cam arm, and cam bearing. The check valve shall utilize a single torsion spring design to minimize pressure drop through the assembly. The check valves shall be modular and shall seal to the main valve body by the use of an O-ring. There shall be no brass or bronze parts used within the check assembly or relief valve. The use of seat screws to retain the check valve seat is prohibited. All internal parts shall be accessible through a single cover on the valve assembly securely held in place by a two-bolt grooved coupling. The differential relief valve shall be of stainless steel construction and shall utilize a rolling diaphragm and no sliding seals. The relief valve shall be bottom mounted and supplied with a steel reinforced sensing hose. The assembly shall include two resilient shutoff valves and four ball type test cocks and a hydraulically balanced bypass line. The bypass line shall include a meter, small diameter reduced pressure zone assembly and isolation valves. The bypass reduced pressure assembly shall have a single bolted on cover and top mounted test cocks. The assembly shall be a Watts Series 994RPDA.

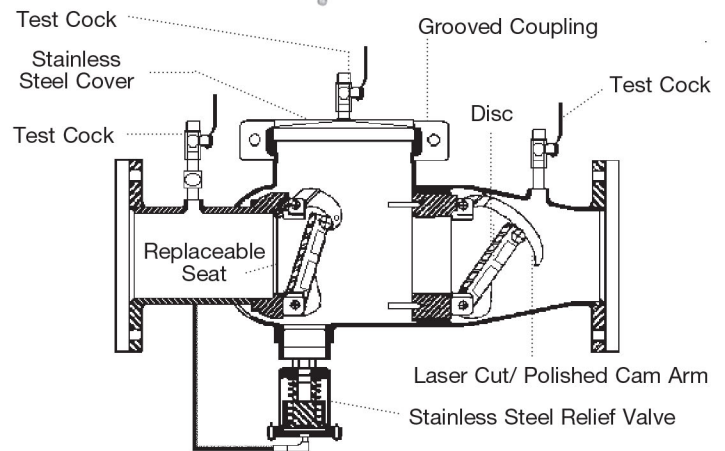
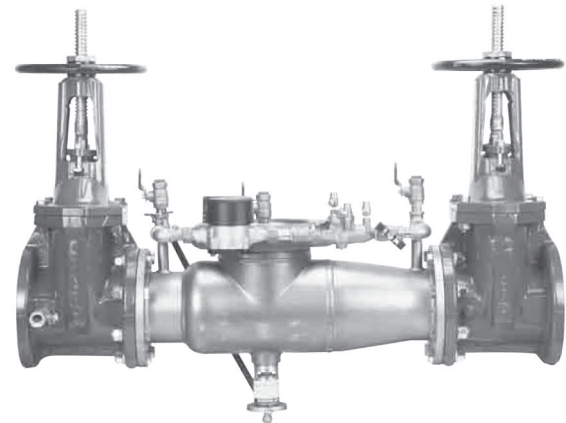

Models

Suffix:

- LF – without shutoff valves
- OSY – UL/FM outside stem and yoke resilient seated gate valves
- *OSY FxG – flanged inlet gate connection and grooved outlet gate connection
- *OSY GxF – grooved inlet gate connection and flanged outlet gate connection
- *OSY GxG – grooved inlet gate connection and grooved outlet gate connection
- CFM – cubic feet per minute meter
- GPM – gallons per minute meter

Available with grooved NRS gate valves - consult factory*

Post indicator plate and operating nut available - consult factory*

*Consult factory for dimensions

Note: The installation of a drain line is recommended. When installing a drain line, an air gap is necessary.

**IMPORTANT: INQUIRE WITH GOVERNING AUTHORITIES
FOR LOCAL INSTALLATION REQUIREMENTS**

**Now Available
WattsBox Insulated Enclosures.**

For more information, send for literature ES-WB.



National Fire
Equipment Ltd.

TORONTO: (905) 761-6355
Toll Free: (800) 267-8508

OTTAWA: (613) 723-6071

VANCOUVER: (604) 420-1131
Toll Free: (800)-667-2138

BURNABY: (604)-299-4498

EDMONTON: (780) 455-3870
Toll Free: (888)-891-1008

CALGARY: (403) 236-5661

MONCTON: (506) 859-7277
Toll Free: (877) 816-3473

MISSISSAUGA: (905) 565-1385

www.nationalfire.com

Materials

All internal metal parts: 300 Series stainless steel
 Main valve body: 300 Series stainless steel
 Check assembly: Noryl®
 Flange dimension in accordance with AWWA Class D

Pressure – Temperature

Temperature Range: 33°F – 110°F (0.5°C – 43°C) continuous
 Maximum Working Pressure: 175psi (12.1 bar)

Capacity

*Typical maximum flow rate (7.5 feet/sec.) **UL rated flow

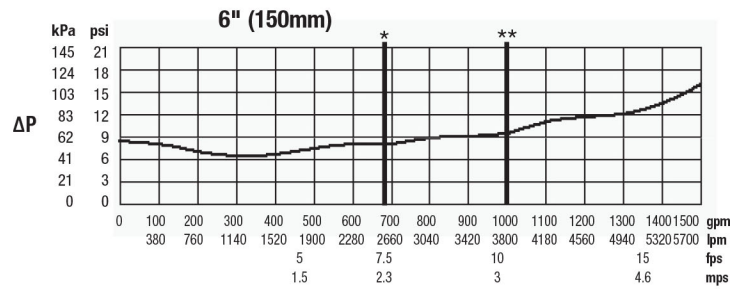
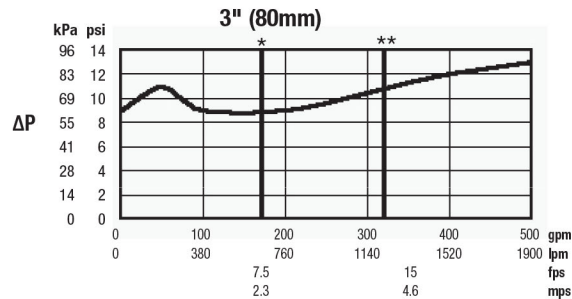
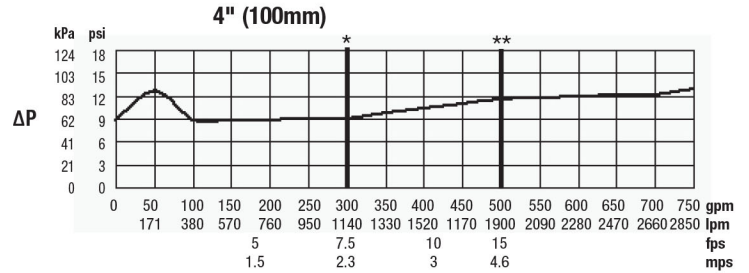
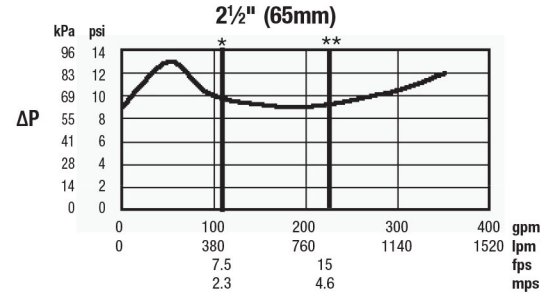

Dimensions – Weights

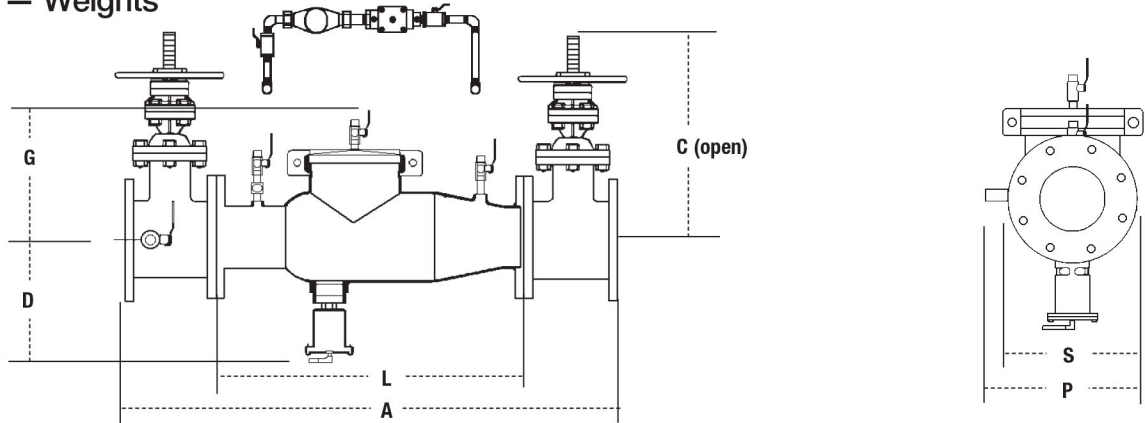

SIZE (DN)		DIMENSIONS				WEIGHTS													
in.	mm	A		C		D		G		L		P		S		with Gates		without Gates	
		in.	mm	in.	mm	in.	mm	in.	mm	in.	mm	in.	mm	in.	mm	lbs.	kgs.	lbs.	kgs.
2 1/2	65	37	940	16 3/8	416	10 1/2	267	10	254	22	559	12 1/2	318	7	178	170	77	61	28
3	80	38	965	18 3/8	479	10 1/2	267	10	254	22	559	13	330	7 1/2	191	205	93	65	29
4	100	40	1016	22 3/4	578	10 1/2	267	10	254	22	559	14 1/2	368	9	229	270	122	67	30
6	150	48 1/2	1232	30 3/8	765	11 1/2	292	11 1/2	292	27 1/2	699	15 1/2	394	11	279	405	184	105	48

Noryl® is a registered trademark of General Electric Company

Standards

AWWA C511-92, CSA B64.5

Approvals



**National Fire
Equipment Ltd.**

TORONTO: (905) 761-6355
 Toll Free: (800) 267-8508
 OTTAWA: (613) 723-6071

VANCOUVER: (604) 420-1131
 Toll Free: (800)-667-2138
 BURNABY: (604)-299-4498

EDMONTON: (780) 455-3870
 Toll Free: (888)-891-1008
 CALGARY: (403) 236-5661

MONCTON: (506) 859-7277
 Toll Free: (877) 816-3473
 MISSISSAUGA: (905) 565-1385

www.nationalfire.com