



National Fire Equipment Ltd.

Pressure Restricting Angle Valves - A155 and A156



A155



A156

Loss pressure calculation

$$\Delta P = \left[\frac{GPM}{C_v} \right]^2$$

ΔP = Differential Pressure (Difference between Inlet and Outlet Pressure) in PSI.

GPM = Water Flow Rate in Gallons per Minute

C_v = Valve Coefficient

A155-A156 1 1/2"

Set Number	Cv
1	4,40
2	6,20
3	6,95
4	7,60
5	7,78
6	8,03
7	10,09
8	12,70
9	13,91
10	16,63
15	19,67
F.O.	28,00

A155-A156 2 1/2"

Set Number	Cv
1	13,90
2	19,60
3	24,20
4	25,50
5	28,10
6	30,05
7	30,90
8	34,08
9	35,78
10	37,60
11	38,40
12	39,45
13	40,45
14	41,80
15	43,39
16	46,80
17	51,20
18	58,36
19	65,60
20	73,32
F.O.	125,00

Description

The valves are capable of adjustment to provide a range of the outlet pressures under flowing condition only.

For Hose Connections to be used on fire protection standpipe system with maximum working pressure up to 300 PSI.

Versions and product codes

Series	Size	Type	Finishing
A155	1 1/2"	Double female - Angle NPT inlet (F) x NPT outlet (F)	Forged Brass Polished Brass Rough Chrome Polished Chrome
	2 1/2"		
A156	1 1/2"	Female x Male hose thread - Angle NPT inlet (F) x Hose outlet (M)	Forged Brass Polished Brass Rough Chrome Polished Chrome
	2 1/2"		

Technical data

Materials

- Body: forged brass CuZn40Pb2 in accordance with European Standard EN 12165 CW617N, similar to American Standard ASTM B124 C37700
- Yield stress of the material in the shape of bar: 360 MPa
- Stress for permanent distortion R(0.2): 138 MPa
- Elongation: 10 %
- Bonnet: forged brass CuZn40Pb2 in accordance with European Standard EN 12165 CW617N, similar to American Standard ASTM B124 C37700
- Stem: brass EN 12164 CW614N similar to American Standard ASTM B124 C37700
- Handwheel: red painted aluminum



300 PSI



LISTED 12HO
175 PSI



12HO
175 PSI

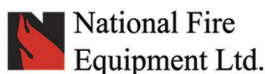

TORONTO: (905) 761-6355
Toll Free: (800) 267-8508

OTTAWA: (613) 723-6071

VANCOUVER: (604) 420-1131
Toll Free: (800)-667-2138

BURNABY: (604)-299-4498

EDMONTON: (780) 455-3870
Toll Free: (888)-891-1008

CALGARY: (403) 236-5661

MONCTON: (506) 859-7277
Toll Free: (877) 816-3473

MISSISSAUGA: (905) 565-1385

www.nationalfire.com



National Fire Equipment Ltd.

Pressure Restricting Angle Valves - A155 and A156

Determining the proper outlet pressure

1- The valves are reducing the downstream water pressure under flowing (residual) condition only.

The valve should not be set to provide less than the minimum pressure required by NFPA 14 while flowing 250 GPM for 2 1/2" size and 100 GPM for 1 1/2" size.

NFPA 14 requires that Standpipe systems shall be hydraulically designed to provide the required water flow rate at a minimum residual pressure of 100 PSI at the outlet of hydraulically most remote 2 1/2" hose connection and 65 PSI at the outlet at the hydraulically most remote 1 1/2" hose station.

Outlet pressures which do not correspond to NFPA 14 requirements must be authorized by local fire department.

There will be a pressure drop due to friction between the outlet and the nozzle. The amount of this loss should be calculated by qualified personnel, to assure that the nozzle receives water pressure sufficient to its design needs.

Note that some fire hose nozzles may not operate properly when valve outlet pressure is set at the 100 PSI minimum authorized in the 2007 edition of NFPA 14.

The installer should consult with the fire authorities concerning pressures needed by their equipment.

The outlet pressures indicated in the curves are at the outlet of the valve.

2- To determine the pressures at the hose nozzle, the hydraulic calculation information provided in NFPA. Fire Protection Handbook should be followed.

3- The valves are designed and Listed to reduce inlet pressures under flowing conditions: see the following graphs.

Authorities having jurisdiction should be consulted to confirm that the outlet pressures and flowrates are acceptable.



Warning.

The graphs are referred only to the indicated conditions of flow and pressure, as tested at Giacomini test station. Should the local codes or the designing Engineer require graphs for different conditions, or the test procedure on the field is specified, please contact the factory or your local representative for alternate graphs to suit field conditions.

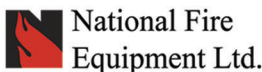
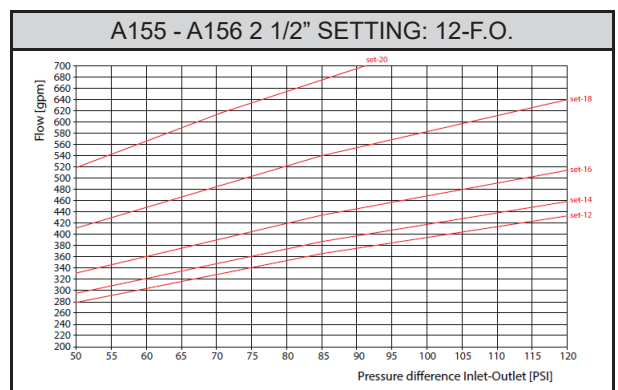
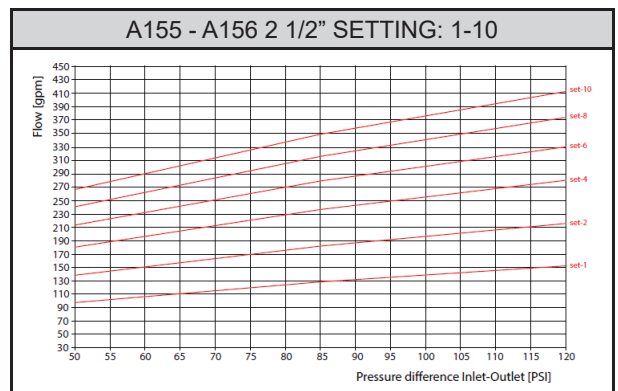
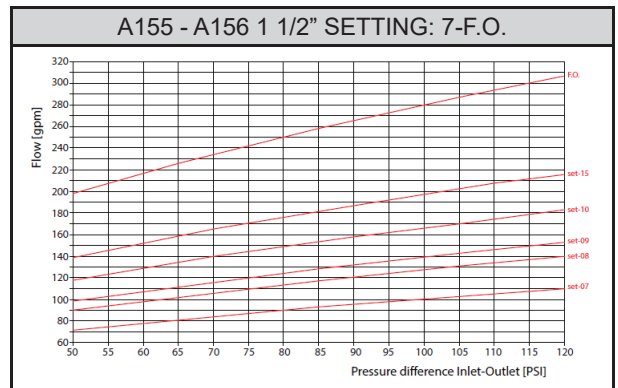
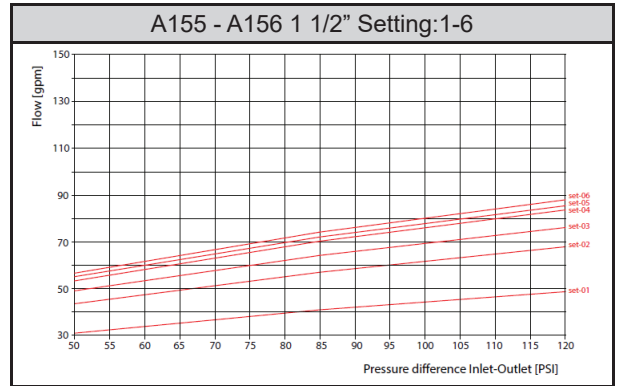

TORONTO: (905) 761-6355
Toll Free: (800) 267-8508

VANCOUVER: (604) 420-1131
Toll Free: (800)-667-2138

EDMONTON: (780) 455-3870
Toll Free: (888)-891-1008

MONCTON: (506) 859-7277
Toll Free: (877) 816-3473

OTTAWA: (613) 723-6071

BURNABY: (604)-299-4498

CALGARY: (403) 236-5661

MISSISSAUGA: (905) 565-1385

www.nationalfire.com



National Fire Equipment Ltd.

Pressure Restricting Angle Valves - A155 and A156

Installation

- 1- Pipe unions or rubber-gasketed fittings are to be installed immediately upstream and downstream of the valve to permit easy replacement.
- 2- Connect the valve to the piping.
- 3- Select setting number from proper graph.
- 4- Close valve hand-tight.
- 5- Loosen set screw in collar.
- 6- Rotate indicator-cap until top collar reaches selected setting number.
- 7- Tighten set screw in collar. Valve is now set.
- 8- To override pressure restriction, pull spring clip. See Fig.1.
 - These valves are intended for use in Class III Standpipe systems.
 - Pipe unions or rubber-gasketed fittings are to be installed immediately upstream of the valve to permit easy replacement.
 - If the valve fail to perform as intended, the valve would need to be replaced. The valves must be installed on threaded end NPT pipe line using appropriate tools through the hexagon at the bottom of the body. During the installation pay attention not to deform the bonnet or other valve parts, as this could compromise the valve functioning. By turning the handle counterclockwise, the valve opens and it closes by turning the handle clockwise. After installation, verify the tightness through a pressure test.

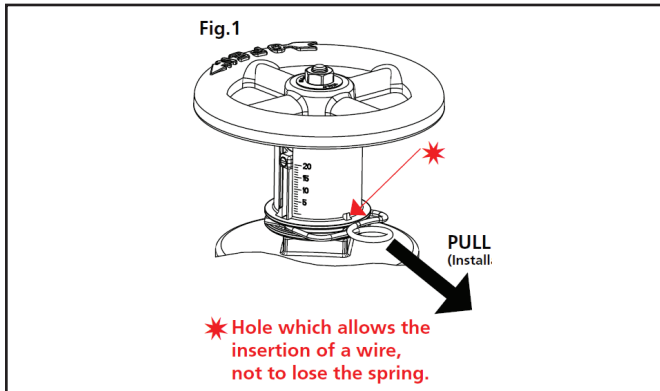

Maintenance

The valves require no special maintenance. Conduct periodic hydraulic tightness test and check the correct manoeuvrability. In case of damage of the seal seat or of the bonnet, the valve must be replaced. However it is recommended to replace the valve after a lifetime of ten years.

Maintenance and testing should be done in accordance with NFPA 25.

- 1- In the event the valve leaks, the test valve should be opened again to flush the valve.
- 2- The valve should be inspected for damage or corrosion annually.
- 3- The valve is not designed to accept replacement parts.
- 4- The system should be drained every two to three years and all valves opened fully and lubricant applied to the valve stem. The valve seat should be inspected for debris.
- 5- The valve should be operated by hand, never using a torque bar or other device to exert pressure. Excess torque may damage the seat and or stem, disc, and other working parts.
- 6- If the valve fails to perform as intended, the valve should be replaced.

Dimensions

A155 - DOUBLE FEMALE - ANGLE

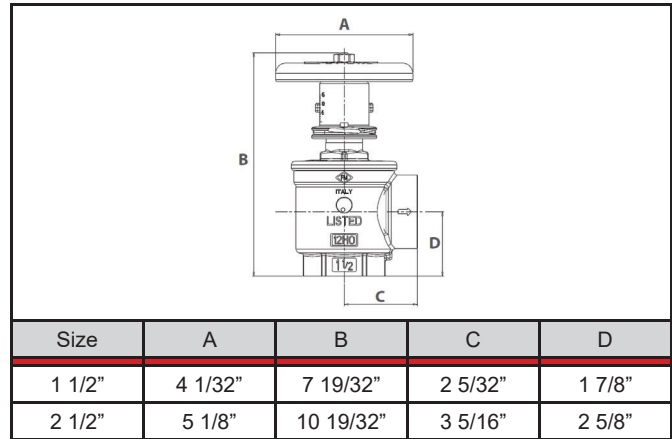

A156 - DOUBLE FEMALE - ANGLE

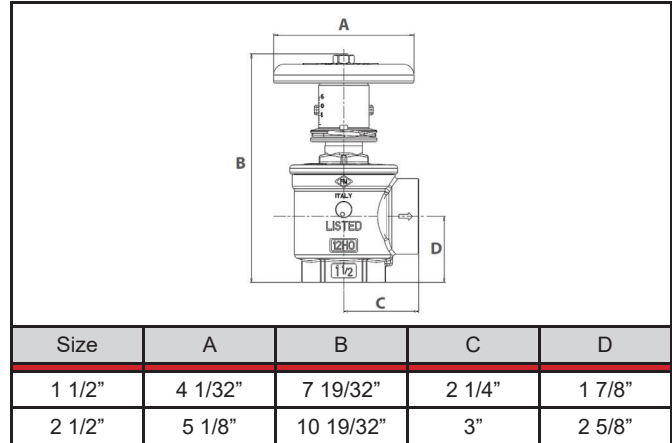

Product specifications

A155 1 1/2"

Angle pressure restricting valves for water pressure control by adjustable flow restriction; forged brass body with 1 1/2" female-female NPT threads and red painted aluminum, handweel. Rated pressure 175 PSI. Complete with spring clip to override the setting when full flow is required.

A155 2 1/2"

Angle pressure restricting valves for water pressure control by adjustable flow restriction; forged brass body with 2 1/2" female-female NPT threads and red painted aluminum, handweel. Rated pressure 175 PSI. Complete with spring clip to override the setting when full flow is required.

A156 1 1/2"

Angle pressure restricting valves for water pressure control by adjustable flow restriction; forged brass body with 1 1/2" female NPT - 1 1/2" male hose thread and red painted aluminum, handweel. Rated pressure 175 PSI. Complete with spring clip to override the setting when full flow is required.

A156 2 1/2"

Angle pressure restricting valves for water pressure control by adjustable flow restriction; forged brass body with 2 1/2" female NPT - 2 1/2" male hose thread and red painted aluminum, handweel. Rated pressure 175 PSI. Complete with spring clip to override the setting when full flow is required.

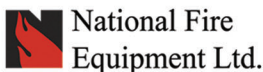

TORONTO: (905) 761-6355
Toll Free: (800) 267-8508

VANCOUVER: (604) 420-1131
Toll Free: (800)-667-2138

EDMONTON: (780) 455-3870
Toll Free: (888)-891-1008

MONCTON: (506) 859-7277
Toll Free: (877) 816-3473

OTTAWA: (613) 723-6071

BURNABY: (604)-299-4498

CALGARY: (403) 236-5661

MISSISSAUGA: (905) 565-1385

www.nationalfire.com