



National Fire Equipment Ltd.

3" STATION MONITOR 1250 GPM FP-1200

SPECIFICATIONS

National Fire/ Fire Pro® station monitors were specifically designed to meet all requirements of municipal and petrochemical applications. The balanced flow single waterway design and precision machining on swivel joints reduces friction loss while improving stream and distance, and ensures ease of operation at all pressure/ flow ranges. Carbon Steel construction with 304 stainless steel swivels. Standard red polyester powder coating inside and out protect against corrosion.

Type 304 stainless steel ball bearings in joints ensure easy movement and reliable operation.

REGULARLY FURNISHED

- 3" Waterway to 2-1/2" Outlet
- Seamless carbon or stainless steel construction
- Low friction loss
- Zerk fitting for lubrication
- 360° horizontal and 120° vertical travel
- 1200 GPM (4542 lpm)

PRODUCT OPTIONS

- Drainage Provisions
- Gauge and Guard
- Metric Flanges
- Parallel Handle
- Shut Off Valve
- Steering Wheel Handle

FINISHES:

Customer Colors _____ (Specify)



FP3F-1200 Shown

Model	Inlet In (mm)	Outlet In (mm)	Weight Lbs (kg)
FP3-1200	3" FLANGE (64)	3" (76) Waterway W/ 2-1/2" (64) Male Thread	52 (24)
FP3 (F/M)-1200	3" FLANGE (64)	3" (76) Waterway W/ 2-1/2" (64) Male Thread	52 (24)
FP4-1200	4" FLANGE (76)	3" (76) Waterway W/ 2-1/2" (64) Male Thread	52 (24)

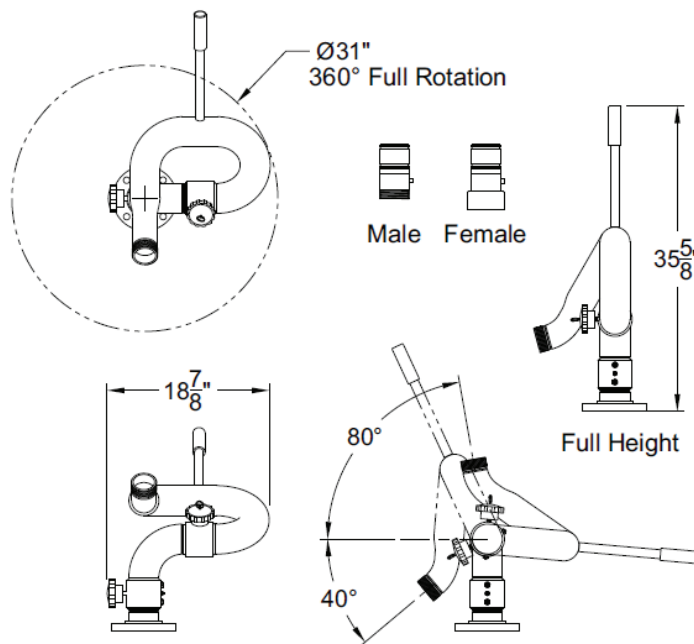

National Fire
Equipment Ltd.

TORONTO: (905) 761-6355
Toll Free: (800) 267-8508

OTTAWA: (613) 723-6071

VANCOUVER: (604) 420-1131
Toll Free: (800)-667-2138

BURNABY: (604)-299-4498

EDMONTON: (780) 455-3870
Toll Free: (888)-891-1008

CALGARY: (403) 236-5661

MONCTON: (506) 859-7277
Toll Free: (877) 816-3473

MISSISSAUGA: (905) 565-1385

www.nationalfire.com