

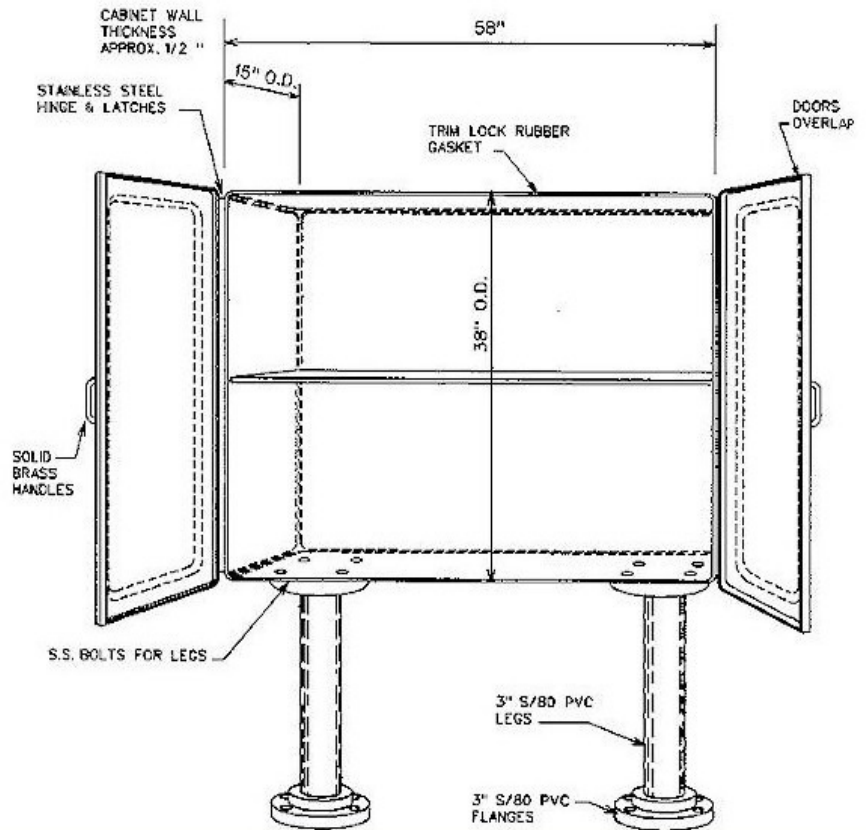

Model FHC-10 Fiberglass Hose Storage Cabinet

Inside Dimensions: 36 1/2" x 57" x 14 1/2"



STANDARD FEATURES:

- Manufactured under USA Patent No. 41898.567
- Used by the USA & Canadian Coast Guard
- Solid Brass Grab Handles
- Full Length Stainless Steel Hinges
- Stainless Steel Rivets and Quick-Opening Latches
- Meets or Exceeds NEMA 4X Rating
- Standard Classifications Emblems
- Choice of UV-Inhibited High Visibility Colors. Standard is Red.
- Chemical Resistant Construction

OPTIONAL FEATURES:

- Easy View Acrylic Window for Verification of Contents
- Lockable Latches
- Fire Retardant Construction
- Custom Design Shelving
- Stainless Steel Grab Handles
- Custom Classification Emblems
- PVC 3" Legs
- Aluminum Angle Support 1 1/2" x 1 1/2" x 1/4"

For more NFE fiberglass cabinets visit our website at
www.nationafire.com