

Model No. CE-950-3-FR

9" X 24" X 6"

RECESSED

STANDARD CONSTRUCTION FEATURES

- 1" Turnback on Front
- Full Glass Panel (Glass Size 5" x 20")
- Grey Baked Enamel Finish
- Accommodates 10lb Dry Chemical Fire Extinguisher

Options

- Break Glass Door & Lock
- Cylinder Lock
- 304 Stainless Steel Front (Satin Finish) & Tub

Rating:

Warnock Hersey International
Test Report WHI-495-1534
2 hour vertical fire rated assembly



FIRE EXTINGUISHER CABINET

FIRE RATED

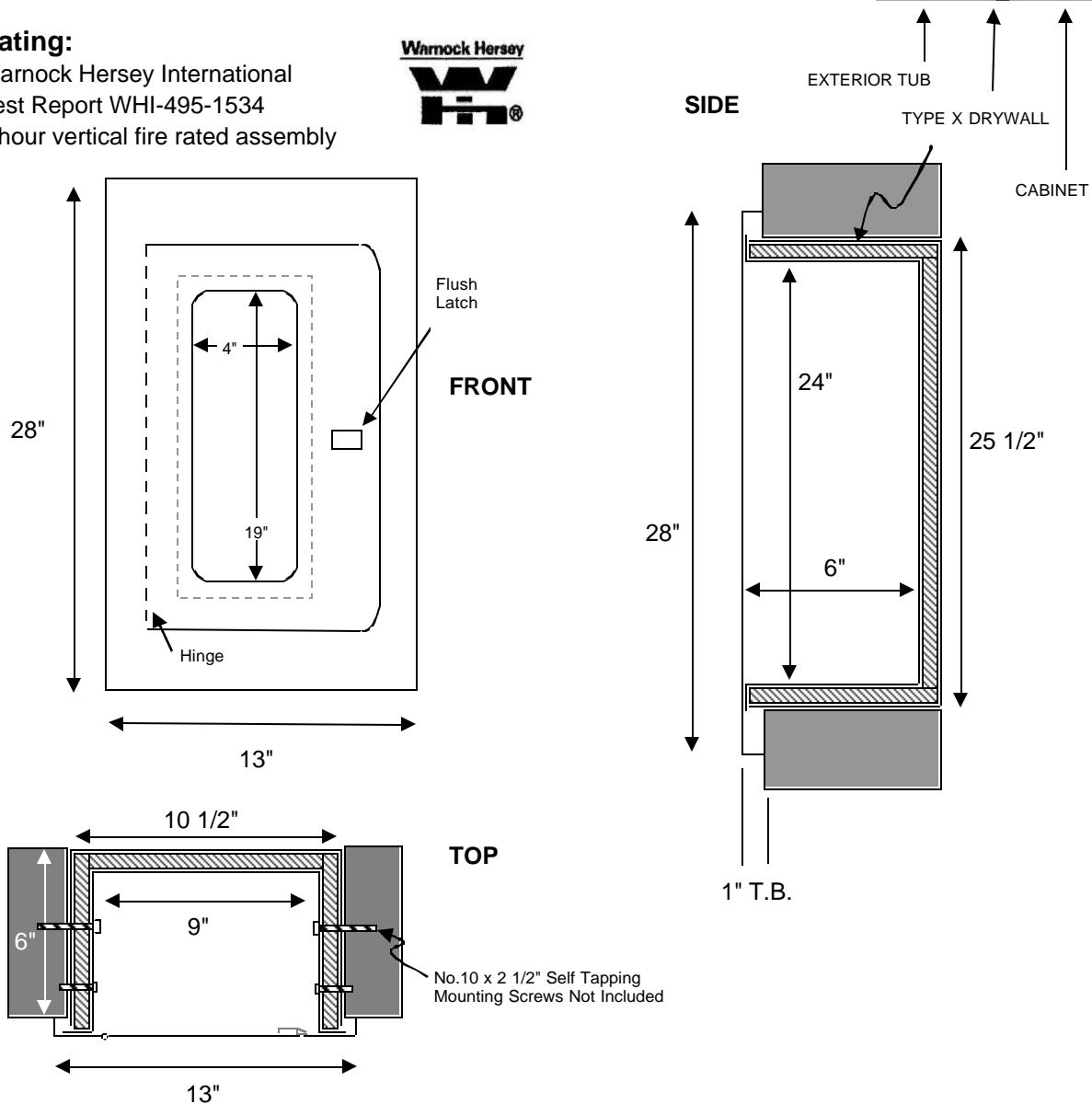

MADE IN CANADA



National Fire Equipment Ltd.
40 Edilcan Dr.
Concord, Ontario
L4K 3S6
Tel: 905 761-6355
Fax: 905 761-6355