



National Fire Equipment Ltd.

CE-950-3-2-SCFR Semi-Recessed 9" w X 24" h X 6" d

STANDARD CONSTRUCTION FEATURES

- 2" Turnback (Front Welded to Tub)
- Full Glass Door w/ Full Length Piano Hinge
- Glass Size 5" x 20" (Glass Opening 4" x 19")
- White Powder Coat Paint Finish (Optional grey shown)
- Accommodates 10lb Dry Chemical Fire Extinguisher
- Stainless Steel Paddle Latch
- Satin Coat Galvanized Exterior Tub w/ Type X Drywall Lining

Rating:

Warnock Hersey International
 Test Report WHI-495-1534
 2 hour vertical fire rated assembly



Installation:

- Rough opening: 10-7/8"W x 26"h x 4-7/8"d
- Installation Instructions are included with each cabinet

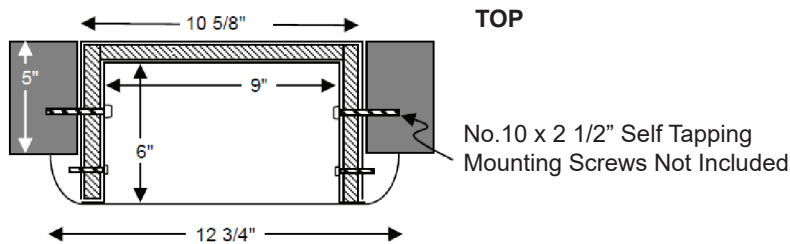
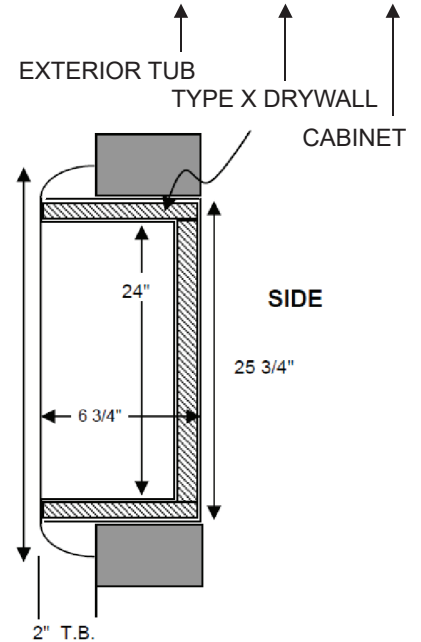
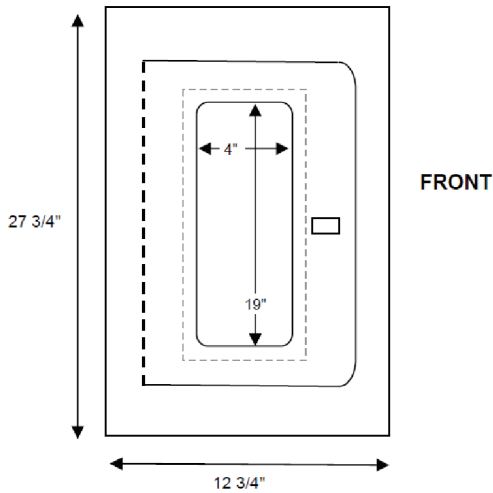
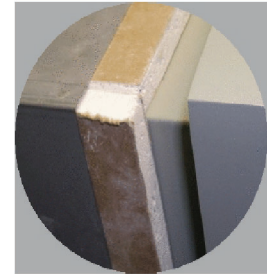

**National Fire
 Equipment Ltd.**

TORONTO: (905) 761-6355
 Toll Free: (800) 267-8508

OTTAWA: (613) 723-6071

VANCOUVER: (604) 420-1131
 Toll Free: (800)-667-2138

BURNABY: (604)-299-4498

EDMONTON: (780) 455-3870
 Toll Free: (888)-891-1008

CALGARY: (403) 236-5661

MONCTON: (506) 859-7277
 Toll Free: (877) 816-3473

MISSISSAUGA: (905) 565-1385

www.nationalfire.com