



National Fire Equipment Ltd.

FIRE EXTINGUISHER CABINETS



N.F.E. 102 & CE-950 Series fire extinguishers cabinets are constructed using the best quality metals and designed to offer durable, safe and practical storage of a wide range of fire extinguisher types and sizes. All cabinets are available from stock in an extensive selection of sizes for recessed or semi-recessed wall mountings.

(Surface mounted cabinets also available, see bottom of this page for specifications)*

Standard units provided with full-length semi-concealed piano hinges, flush stainless steel door latches and completely finished with a powder coated paint. Optional door and trim available from stock in stainless steel with a No. 4 satin finish.+ All stainless steel cabinets are standard with fully concealed "SOSS" hinges. Coloured stainless steel, mirrored finishes, bronze or brass materials also available.

For more cabinet options see pages CAB-02 to CAB-04.



Model CE-950-5
(Semi Recessed Cabinet)

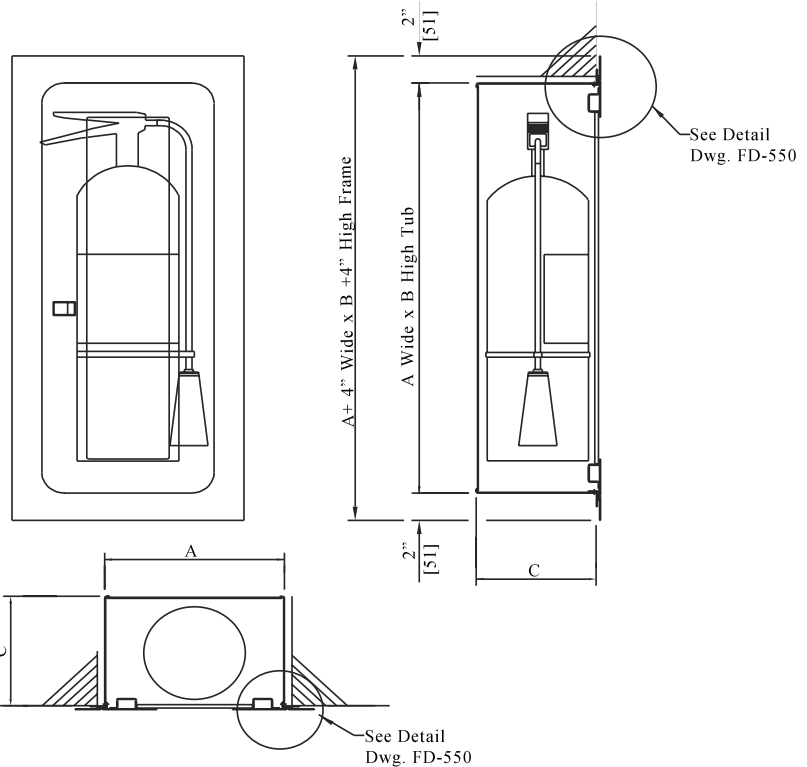

Model	Tub Dimensions A=Width, B=Height, C=Depth	Mounting Type	Standard Turn Back	Front Section Adjustment	Minimum Wall Depth	Fire Extinguisher Maximum
102RS	8" x 17" x 5" (203mm x 432mm x 127mm)	Semi-Recessed	1" (25mm)	None (welded to tub)	4" (102mm)	5 lbs. Dry Chem.
102F	8" x 17" x 5" (203mm x 432mm x 127mm)	Recessed	1/4" (6mm)	None (welded to tub)	5" (127mm)	5 lbs. Dry Chem.
CE-950-1	14 1/2" x 30" x 4" (368mm x 762mm x 102mm)	Semi-Recessed	1" (25mm)	2" (51mm)	4" (102mm)	20 lbs. Dry Chem.
CE-950-2	10" x 30" x 8" (254mm x 762mm x 203mm)	Recessed	1/2" (13mm)	2" (51mm)	8" (203mm)	10 lbs. CO2
CE-950-3	9" x 24" x 6" (229mm x 610mm x 152mm)	Recessed	1/4" (6mm)	None (welded to tub)	6" (152mm)	10 lbs. Dry Chem.
CE-950-3-2	9" x 24" x 6" (229mm x 610mm x 152mm)	Semi-Recessed	2" (51mm)	None (welded to tub)	4" (102mm)	10 lbs. Dry Chem.
CE-950-4	9" x 27" x 8" (229mm x 686mm x 203mm)	Recessed	1/4" (6mm)	None (welded to tub)	8" (203mm)	20 lbs. Dry & 6L Class K
CE-950-5	12" x 30" x 8" (305mm x 762mm x 203mm)	Recessed	1/2" (13mm)	2" (51mm)	8" (203mm)	10 lbs. CO2
CE-950-6	12" x 35" x 8" (305mm x 889mm x 203mm)	Recessed	1/2" (13mm)	2" (51mm)	8" (203mm)	15 lbs. CO2

*Above cabinets available in surface mounted styles. To specify add the suffix "-SUR" to the above model number. (ie: 102RS-SUR)

*Note: CE-950-1, not available in surface mount. + Stainless steel Cabinets available. To specify add the suffix "-SS". (ie: 102RS-SS)

40 Edilcan Drive, Concord, Ontario L4K 3S6 - Tel: (905) 761-6355 - Fax: (905) 761-6458 - 1-800-267-8508
website: www.nationalfire.com



National Fire Equipment Ltd.

FIRE EXTINGUISHER CABINETS

Specifications:

Model 102RS: Provide and install N.F.E. Model 102RS (8" x 17" x 5") semi-recessed fire extinguisher cabinet constructed of 22 ga. (.76mm) steel tub and 16 ga. (1.57mm) steel door & trim with 1" (25mm) return frame, a full length semi-concealed piano hinge and flush stainless steel door latch. Entire cabinet finished in powder coated paint and glazed with $\frac{3}{16}$ " (5mm) clear glass.

Model 102F: Provide and install N.F.E. Model 102F (8" x 17" x 5") recessed fire extinguisher cabinet constructed of 22 ga. (.76mm) steel tub and 16 ga. (1.57mm) steel door & trim with $\frac{1}{4}$ " (6mm) return frame, a full length semi-concealed piano hinge and flush stainless steel door latch. Entire cabinet finished in powder coated paint and glazed with $\frac{3}{16}$ " (5mm) clear glass.

Model CE-950-1: Provide and install N.F.E. Model CE-950-1 (14 $\frac{1}{2}$ " X 30" X 4") semi-recessed fire extinguisher cabinet constructed of 18 ga. (1.19mm) steel tub and 14 ga. (2mm) steel door & trim with 1" (25mm) return frame, a full length semi-concealed piano hinge and flush stainless steel door latch. Front section to have full 2" (51mm) adjustment to wall. Viewing area to be provided with a plastic bubble canopy. Entire cabinet finished in powder coated paint.

Model CE-950-2: Provide and install N.F.E. Model CE-950-2 (10" X 30" X 8") recessed fire extinguisher cabinet constructed of 18 ga. (1.19mm) steel tub and 14 ga. (2mm) steel door & trim with $\frac{1}{2}$ " (13mm) return frame, a full length semi-concealed piano hinge and flush stainless steel door latch. Front section to have full 2" (51mm) adjustment to wall. Entire cabinet finished in powder coated paint and glazed with $\frac{3}{16}$ " (5mm) clear glass.

Model CE-950-3: Provide and install N.F.E. Model CE-950-3 (9" X 24" X 6") recessed fire extinguisher cabinet constructed of 22 ga. (.76mm) steel tub and 16 ga. (1.57mm) steel door & trim with $\frac{1}{4}$ " (6mm) return frame, a full length semi-concealed piano hinge and flush stainless steel door latch. Entire cabinet finished in powder coated paint and glazed with $\frac{3}{16}$ " (5mm) clear glass.

Model CE-950-3-2: Provide and install N.F.E. Model CE-950-3-2 (9" X 24" X 6") semi-recessed fire extinguisher cabinet constructed of 22 ga. (.76mm) steel tub and 16 ga. (1.57mm) steel door & trim with 2" (51mm) return frame, a full length semi-concealed piano hinge and flush stainless steel door latch. Entire cabinet finished in powder coated paint and glazed with $\frac{3}{16}$ " (5mm) clear glass.

Model CE-950-4: Provide and install N.F.E. Model CE-950-4 (9" X 27" X 8") recessed fire extinguisher cabinet constructed of 22 ga. (.76mm) steel tub and 16 ga. (1.57mm) steel door & trim with $\frac{1}{4}$ " (6mm) return frame, a full length semi-concealed piano hinge and flush stainless steel door latch. Entire cabinet finished in powder coated paint and glazed with $\frac{3}{16}$ " (5mm) clear glass.

Model CE-950-5 & CE-950-6: Provide and install N.F.E. Model CE-950-5 (12" X 30" X 8") OR CE-950-6 (12" X 35" X 8") recessed fire extinguisher cabinet constructed of 18 ga. (1.19mm) steel tub and 14 ga. (2mm) steel door & trim with $\frac{1}{2}$ " (13mm) return frame, a full length semi-concealed piano hinge and flush stainless steel door latch. Front section to have full 2" (51mm) adjustment to wall. Entire cabinet finished in powder coated paint and glazed with $\frac{3}{16}$ " (5mm) clear glass.



**Model CE-1000
Outdoor Cabinet**

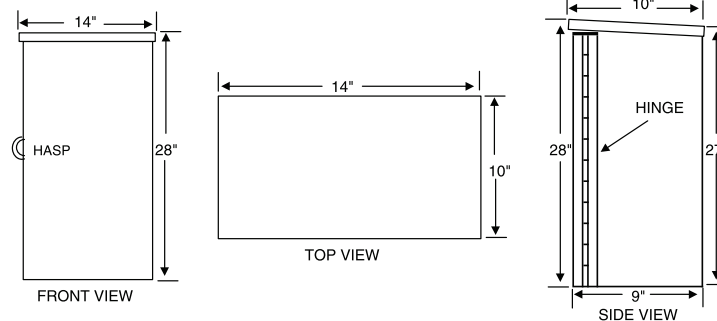

Model CE-1000

Outdoor Fire Extinguisher Cabinet designed to withstand the rigors of harsh Canadian winters. Standard with sloped roof and weatherproof gasketing around door jam. Welded constructed 16 gauge galvanized steel and finished with red powder coated paint. Full-length stainless steel piano hinge, full metal door with stainless steel paddle latch w./ 151 keyed cylinder lock. Accommodates up to a 30 lbs. cartridge operated dry chemical extinguisher.