



National Fire Equipment Ltd.

VALVE CABINETS AND COMBINATION CABINETS



Model C-975

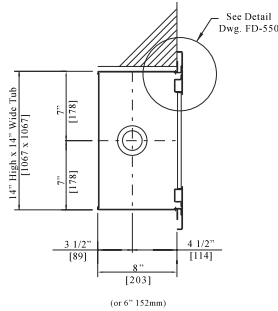

Model C-975:

Designed to store 2 1/2" (65mm) end of line fire hose valves. Same construction features as N.F.E. fire hose cabinets, these top quality valve cabinets are available with a variety of wall mountings, door styles and finishes. Standard dimensions 14" x 14" x 8" (356mm x 356mm x 203mm). Available with vandal protection features. See pages CAB-02 to CAB-04 for cabinet options. Also available in 6" (152mm) depth for 1 1/2" (38mm) hose valve. (Model C-975-B)

WARNING: Standard baked enamel cabinets are not designed for outdoor applications.

Depending on environment use epoxy coatings, galvanized, stainless steel or fiberglass materials. Contact our customers service representatives for assistance.



Model CV-200

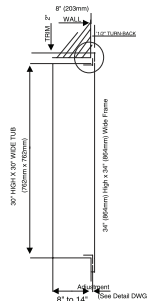

Model CV-200

Sprinkler or Standpipe zone control cabinets are available with the same features as Knight Hose cabinets. Standard size is 30" x 30" x 12" (762mm x 762mm x 304mm) but also available in 8", 10", and 14" depths. (203mm, 254mm, 356mm depths).

Zone control valve cabinets normally supplied with full metal doors.

WARNING: Standard baked enamel cabinets are not designed for outdoor applications.

Depending on environment use epoxy coatings, galvanized, stainless steel or fiberglass materials. Contact our customers service representatives for assistance.

Specifications for C-975 & CV-200:

Recessed Valve Cabinets shall be N.F.E. Model C ____, ____, ____, ____" 18 gauge (1.19mm) tubs and 14 gauge (2mm) fronts with baked enamel corrosion protected steel. Doors with reinforced hollow channel construction. Front section to have full 2" (51mm) adjustment and complete with full length semi-concealed piano hinges and Model SMSS stainless steel door latch. (Stainless steel front to be constructed of 304 stainless steel with #4 satin finish and fully concealed SOSS hinges)

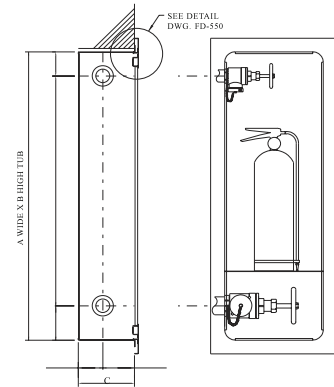

Model C-975E

Model CV-975E

Combination Cabinets designed to accommodate hose valves and extinguishers within a complete storage unit. Fire extinguishers sit on heavy gauge shelves with fire department valve housed in separate compartment. Constructed with the same features as N.F.E. hose cabinets and available with a variety of wall mountings, door styles and finishes.

See pages CAB-02 & CAB-04.

Specifications for Combination Valve / Extinguisher Cabinets:

Recessed Combination Valve & Extinguisher Cabinets shall be N.F.E. Model C-975E ____, ____, ____, ____" 18 gauge (1.19mm) steel tubs with welded shelf to sit fire extinguisher. Fronts constructed of 14 gauge (2mm) steel. The entire cabinet supplied with a shop coat of baked enamel paint. Doors with reinforced hollow channel construction. Front section to have full 2" (51mm) adjustment and complete with full length semi-concealed piano hinges and Model SMSS stainless steel door latch. (Stainless steel front to be constructed of 304 stainless steel with #4 satin finish and three fully concealed SOSS hinges)

Model	Tub Dimensions A=Width, B=Height, C=Depth	Outside Frame Dimensions	Mounting Type	Minimum Wall Depth	Fire Extinguisher Maximum	Valve Maximum
C-975	14" x 14" x 8" (356mm x 356mm x 203mm)	A+4" (102mm) x B+4" (102mm)	Recessed	8" (203mm)	None	2 1/2" (65mm)
CV-200	30" x 30" x (C = 8" or 10" or 12" or 14")	A+4" (102mm) x B+4" (102mm)	Recessed	From 8" to 14"	Sprinkler & Standpipe Zone Control Valve	
C-975E	14" x 42" x 8" (356mm x 1067mm x 203mm)	A+4" (102mm) x B+4" (102mm)	Recessed	8" (203mm)	20 lbs. Dry Chem.	2 1/2" (65mm) bottom section
C-975E-10	10" x 30" x 6" (254mm x 762mm x 152mm)	A+4" (102mm) x B+4" (102mm)	Recessed	6" (152mm)	10 lbs. Dry Chem.	1 1/2" (38mm) bottom section
C-975ED	14" x 42" x 8" (356mm x 1067mm x 203mm)	A+4" (102mm) x B+4" (102mm)	Recessed	8" (203mm)	10 lbs. Dry Chem.	1 1/2" (38mm) top section 2 1/2" (65mm) bottom section

Surface Cabinets available. To specify add the suffix "-SUR" to the above model number (ie: C-975-SUR)
Stainless Steel Cabinets available. To specify add the suffix "-SS" to the above model numbers (ie: C-975-SS)

40 Edilcan Drive, Concord, Ontario L4K 3S6 - Tel: (905) 761-6355 - Fax: (905) 761-6458 - 1-800-267-8508

website: www.nationalfire.com

